

Unicont SPb Ltd

**NMEA 0183 Amplifier-distributor
Unit With Integrated Combiner
ADU-202**

Technical Documentation

(202-2-06072012)

St. Petersburg
2012

Table of Contents

1. GENERAL INFORMATION	4
2. DELIVERY SET	4
3. TECHNICAL SPECIFICATIONS	4
4. DEVICE'S OPERATING MODES	5
5. DEVICE'S INSTALLATION.....	9
6. COMBINING MODE CONFIGURATION.....	12
7. TRANSPORTATION AND STORAGE	13
8. RECYCLING	14
9. WARRANTY	15
10. DATE OF PACKING.....	16
11. ACCEPTANCE DETAILS	16
12. DATE OF COMMISSIONING	16

This Operating Manual applies to the ADU-202 NMEA 0183 Amplifier-distributor Unit With Integrated Combiner.

This Manual is intended to assist in the familiarization with the design, operating principles and procedures established for the convection heater during its intended use or maintenance. This Manual can also be used as a source of information about сведений об устройстве to draw up corresponding sections in the operational documentation for the equipment, в которой this product may be used as its component part.

All information contained in this Manual is distributed by the company for information purposes only. The information is subject to changes without notification to consumers; the information may contain errors or discrepancies. The information provided may not contain obligations on the part of Unicont SPb Ltd

1. General Information

Device ADU-202 is intended for amplification and distribution of signals NMEA 0183 versions 1 and 2, and also other signals on serial data transmitting.

Also device ADU-202 has integrated combiner, which provides combination of received NMEA messages. Combined message transmit to one or two output groups (it depends of jumpers position on PCB).

2. Delivery Set

1. Amplifier-distributor unit ADU-202	1 piece
2. CD with software	1 piece
3. Operation manual	1 piece

3. Technical specifications

Electrical Specification:

Power voltage	24 VDC
Power consumption	5 W
Protection against reverse voltage and short circuit.	
Galvanic isolation of inside scheme from power circuit.	

Output's Specification:

Number of inputs:	2 (A and B)
Number of interfaces of each input:	2 (RS-232 and RS-422)
Maximum baud rate:	up to 230400 bps
Inputs are opt coupled:	

Input's Specification:

Number of output groups:	2 (A and B)
Number of outputs in each group:	4
Number of interfaces in each output:	2 (RS-232 and RS-422)
Total number of device's outputs is:	16
All outputs are opt coupled	

General Specification:

Overall dimensions:	244 x 144 x 55 mm
Weight:	no more than 2 kg
Temperature of operation:	-25..+55 °C
Storage temperature:	-55..+75 °C

4. Device's operating modes

Device ADU-202 may operate in 5 different modes. Each mode is defined by device's jumpers' position.

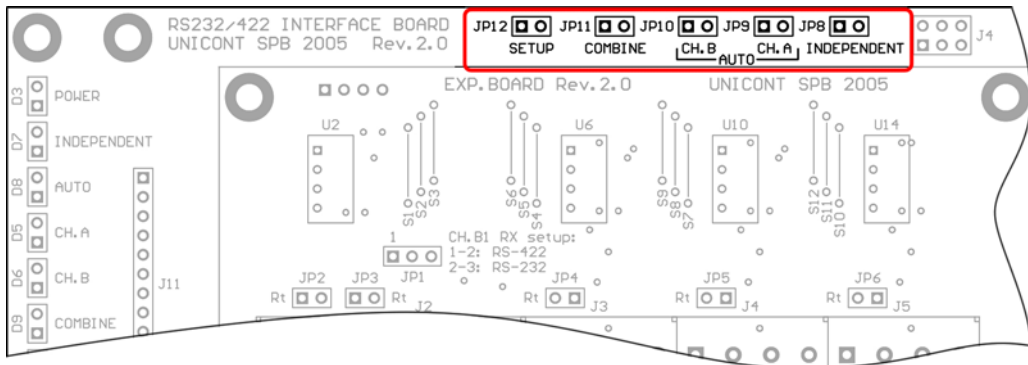

Combining mode

Combined data from inputs A and B is transmitted to the output groups A and B (outputs A1, A2, A3, A4 and B1, B2, B3, B4).

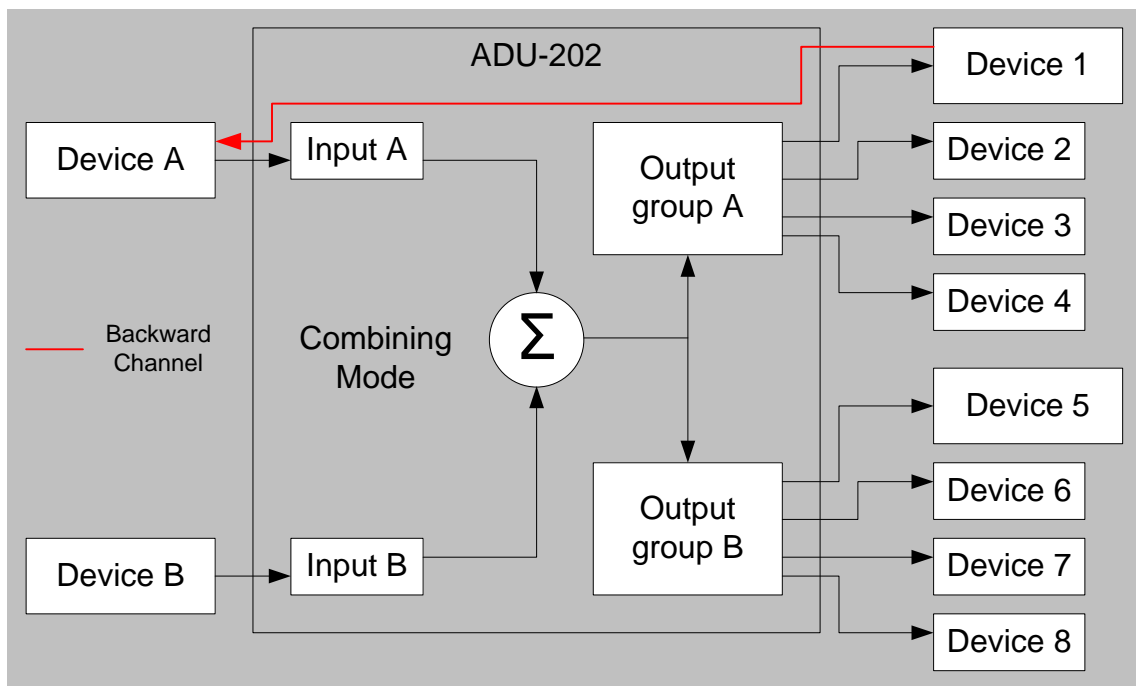

Set up jumpers how it is shown below to set device's operating mode:

JP8 «INDEPENDENT»	JP9 «CH.A»	JP10 «CH.B»	JP11 «COMBINE»	JP12 «SETUP»
			X	

Independent mode

Device transmit received data from input A to output group A (outputs A1, A2, A3, A4), received data from input B is transmitted to output group B (outputs B1, B2, B3, B4).

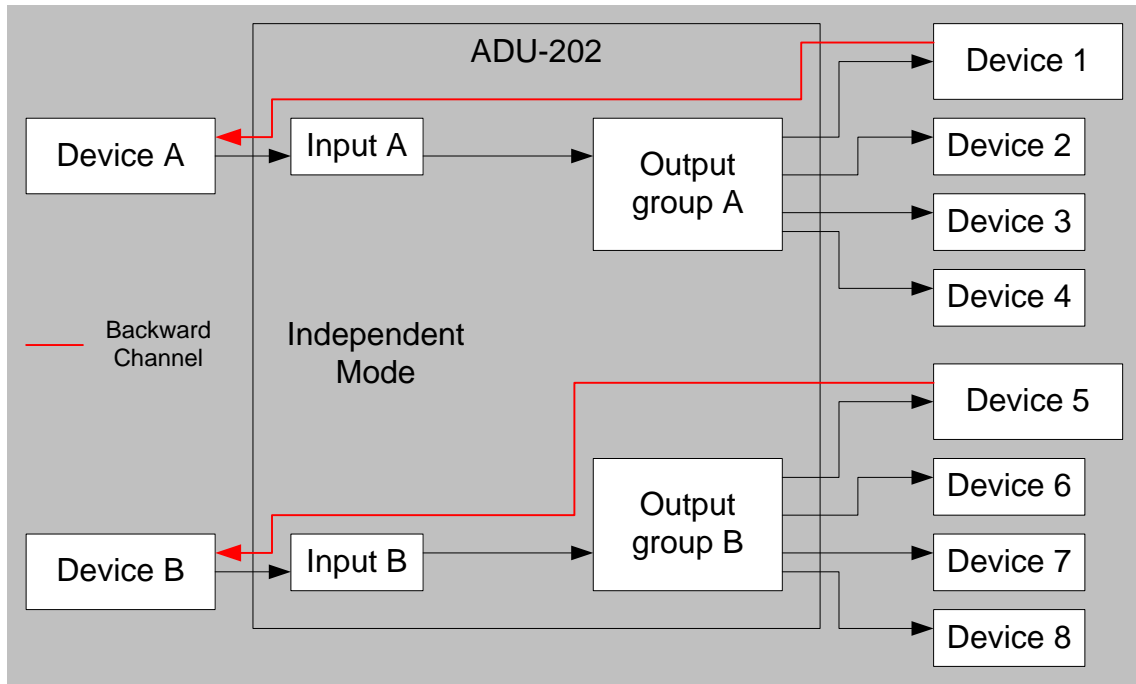

Set up jumpers how it is shown below to set device's operating mode:

JP8 «INDEPENDENT»	JP9 «CH.A»	JP10 «CH.B»	JP11 «COMBINE»	JP12 «SETUP»
X				

Distributor with manual switching of active channel mode

Device transmits data from active input channel (A or B) to output groups A and B (outputs A1, A2, A3, A4 and B1, B2, B3, B4).

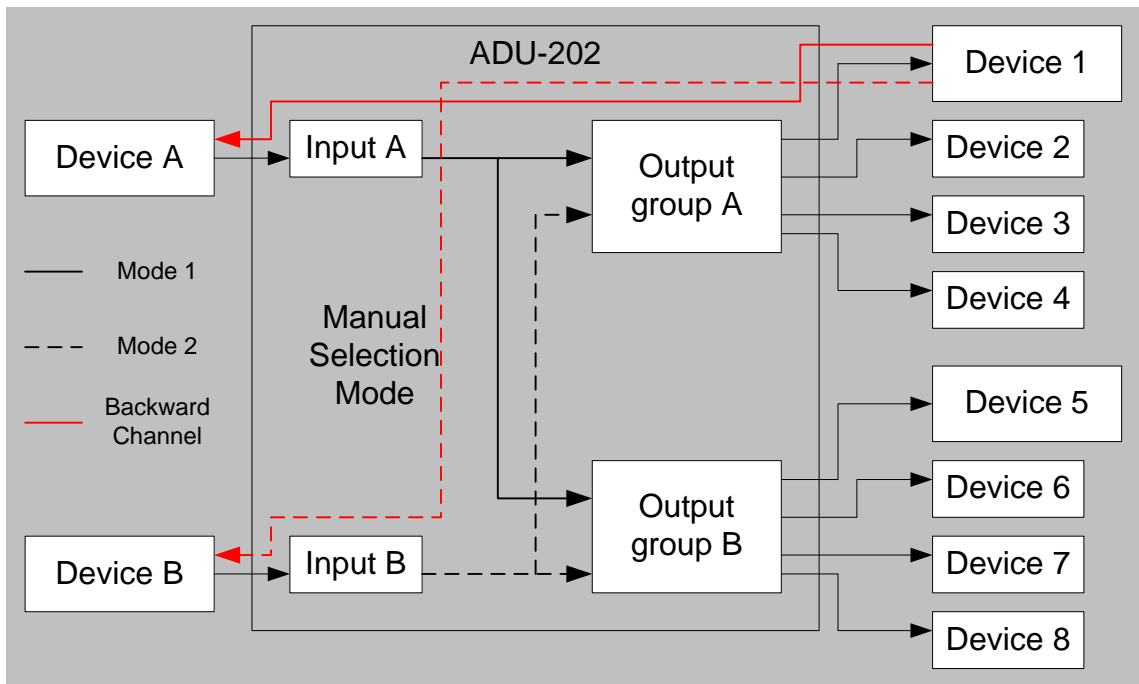

Set up jumpers how it is shown below to set device's operating mode:

Active channel A:

JP8 «INDEPENDENT»	JP9 «CH.A»	JP10 «CH.B»	JP11 «COMBINE»	JP12 «SETUP»
	X			

Active channel B:

JP8 «INDEPENDENT»	JP9 «CH.A»	JP10 «CH.B»	JP11 «COMBINE»	JP12 «SETUP»
		X		

Distributor with automatic selection of active channel mode

Device transmit data from active input channel (A or B) to output groups A and B (outputs A1, A2, A3, A4 and B1, B2, B3, B4). Active channel is selected automatically. If device receives no data from channel A, then device switches to channel B.

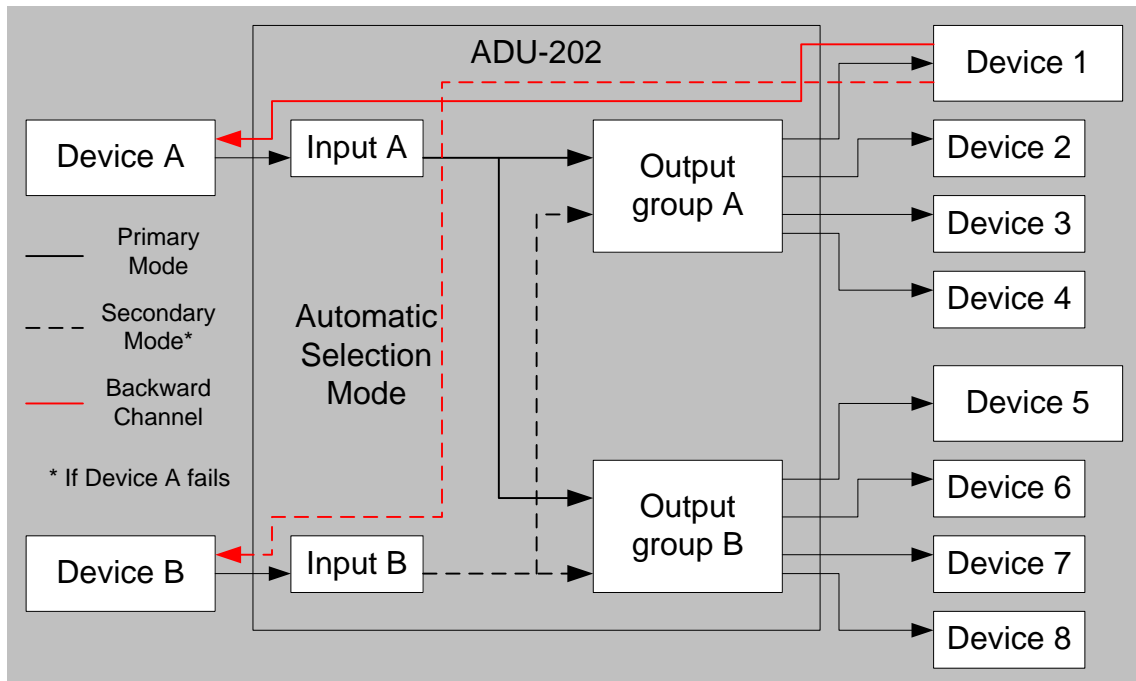

Set up jumpers how it is shown below to set device’s operating mode:

JP8 «INDEPENDENT»	JP9 «CH.A»	JP10 «CH.B»	JP11 «COMBINE»	JP12 «SETUP»

CRC-checking mode

In this mode ADU-202 operates same as “Distributor with automatic selection of active channel mode” but switching to input channel “B” occurs when CRC of a incoming message is invalid. To use this mode parameters of the input interfaces should be adjusted as it describes in chapter 5.

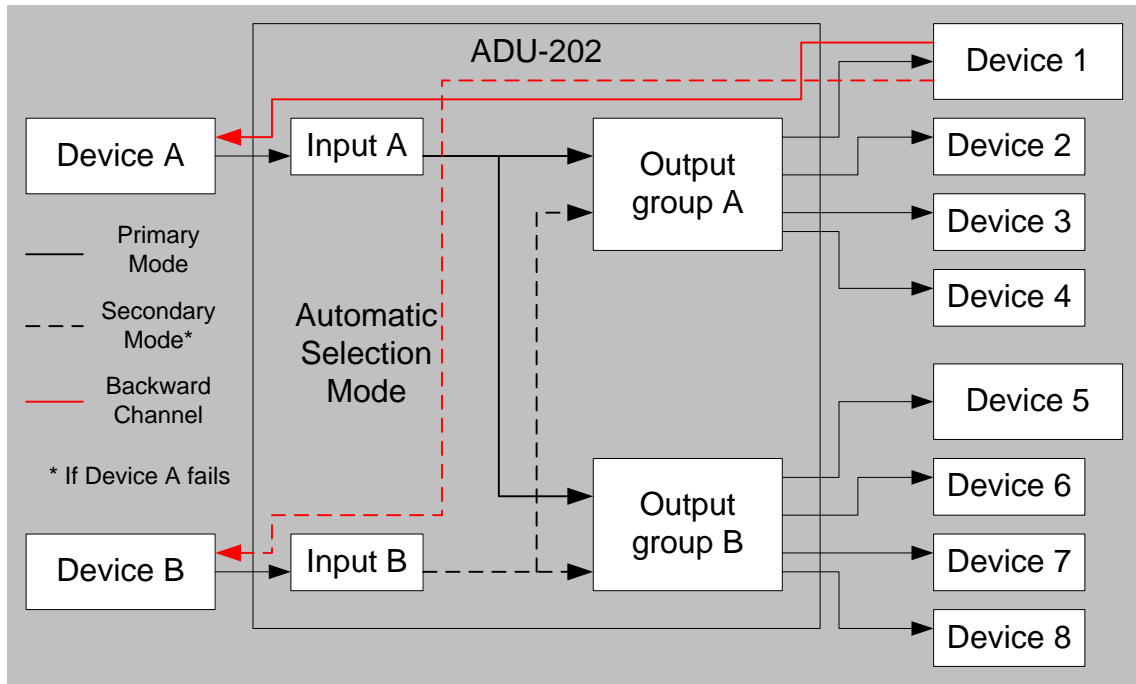

Set up jumpers how it is shown below to set device's operating mode:

JP8 «INDEPENDENT»	JP9 «CH.A»	JP10 «CH.B»	JP11 «COMBINE»	JP12 «SETUP»
X			X	

5. Device's installation

It is recommended to install the device in the following order:

1. Choose the place for the device installation to provide an easy cables admission and their ends cutting. One of the best places is a vertical wall inside a ship;
2. Fix strongly ADU-202 case on a vertical wall and with an effort of a hand check up the security of attachment (for overall dimensions see Figure 1);
3. Remove the body face;
4. Route and pass connecting cables from external devices through cutout, disposed on the ADU-202 bottom part;
5. Connect passed cables to the corresponding plugs on board:
 - wires from NMEA 0183 sources must be connected to the terminal blocks CHANNEL A I/O (primary data source) and CHANNEL B I/O (secondary data source).
 - wires from NMEA 0183 data receivers must be connected to the terminal blocks CHANNEL.A1 I/O, CH.A2, CH.A3, CH.A4 and CHANNEL.B1 I/O, CH.B2, CH.B3, CH.B4.
 - power supply must be connected to the terminal block "12/24VDC".

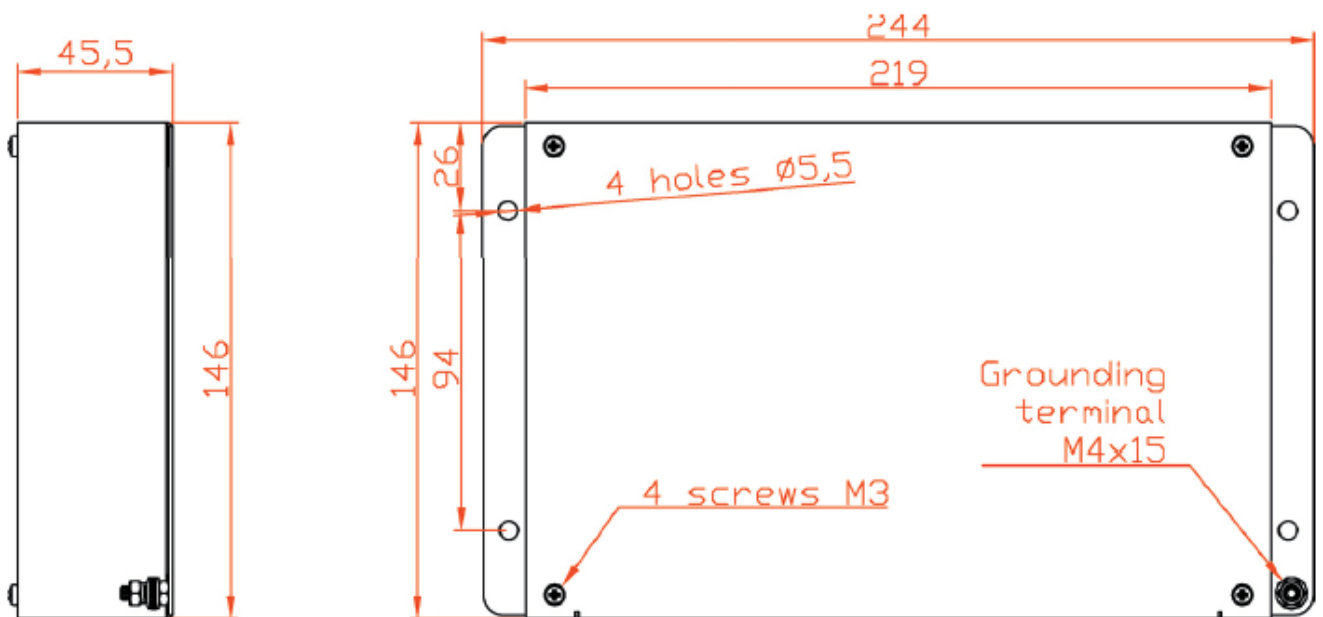

Figure 1 ADU-202 dimensions drawing

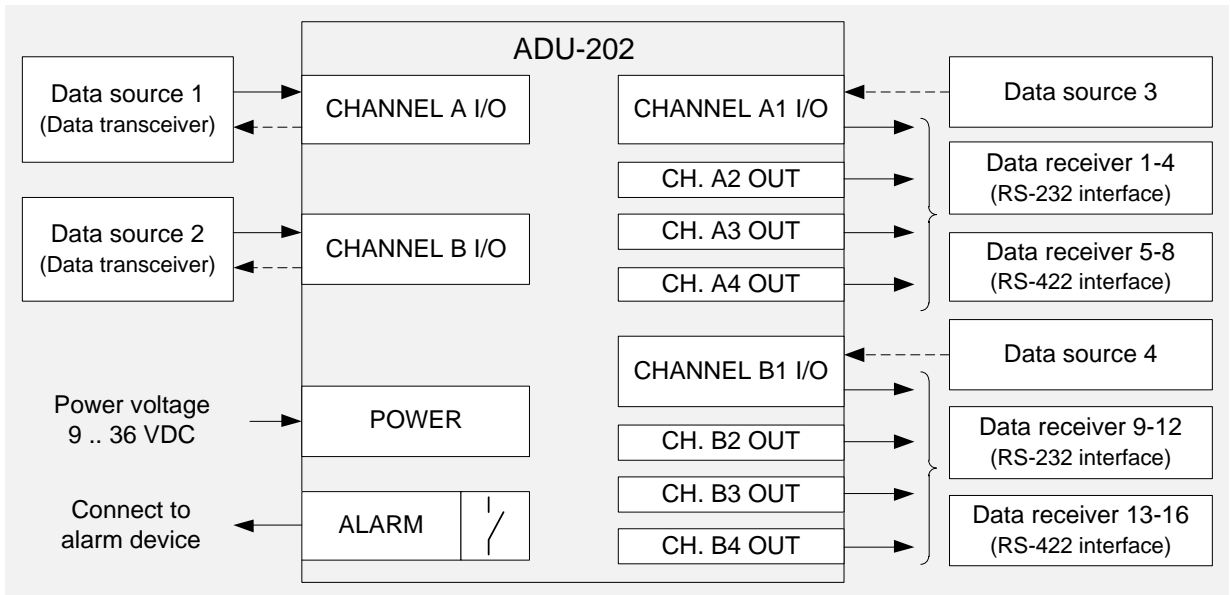

Figure 2 Connection diagram of external devices.

Connection diagram. Ports: “Channel A I/O”, “Channel B I/O”

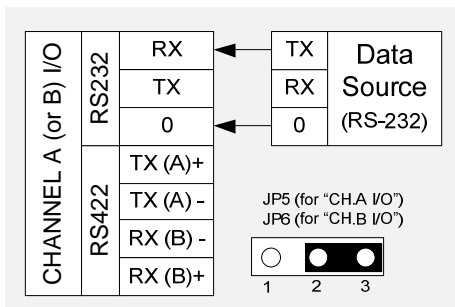

Figure 3 Data source connection on RS-232 interface.

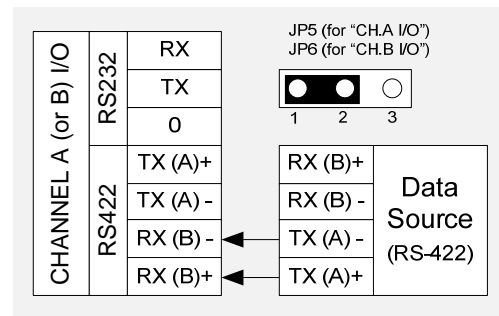

Figure 4 Data source connection on RS-422 interface.

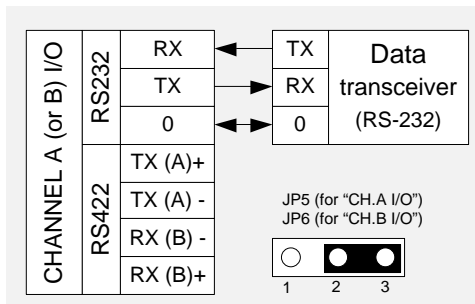

Figure 5 Data transceiver connection on RS-232 interface.

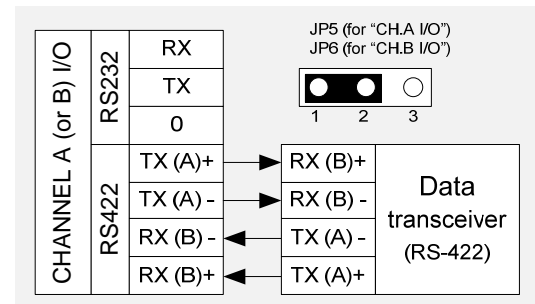

Figure 6 Data transceiver connection on RS-422 interface.

Connection diagram. Ports: "Channel A1 I/O", "Channel B1 I/O"

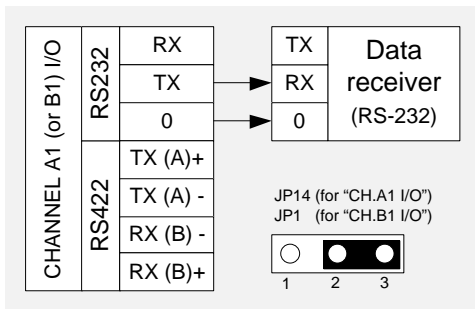

Figure 7 Data receiver connection on RS-232 interface.

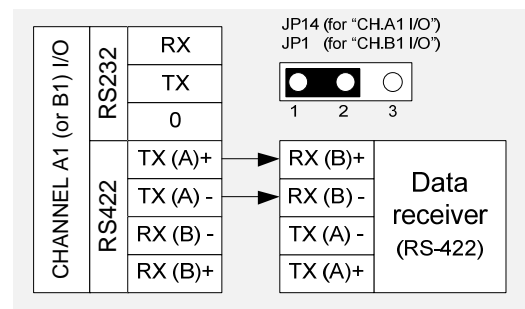

Figure 8 Data receiver connection on RS-422 interface.

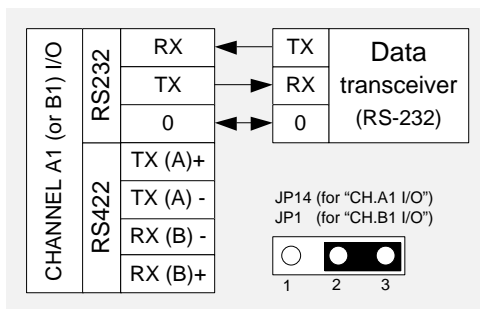

Figure 9 Data transceiver connection on RS-232 interface.

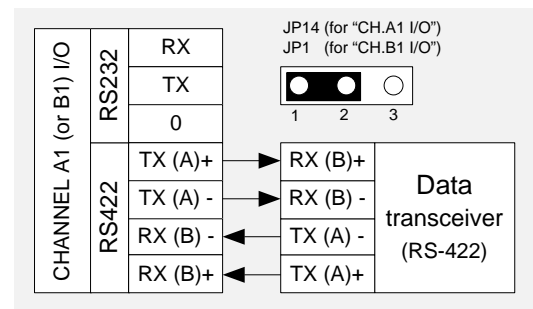

Figure 10 Data transceiver connection on RS-422 interface.

Connection diagram of the output ports.

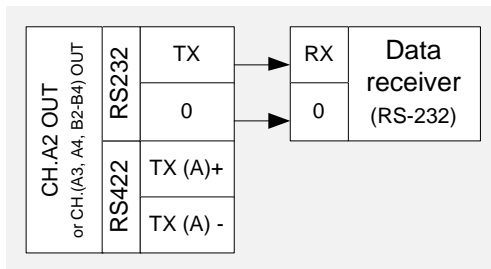

Figure 11 Data receiver connection on RS-232 interface.

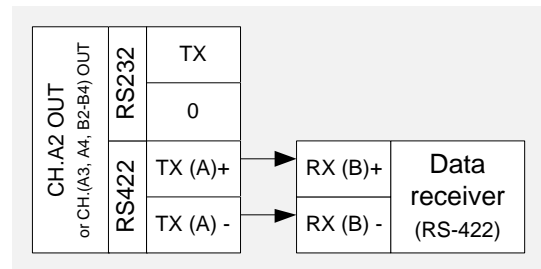

Figure 12 Data receiver connection on RS-422 interface.

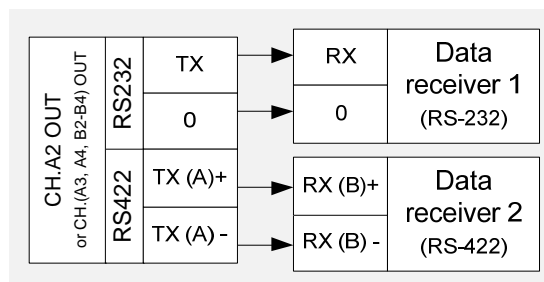

Figure 13 Data receiver connection on both interfaces (RS-232 and RS-422).

6. Combining Mode Configuration

Configuration of the ADU-202 combining mode is carried out with special software. This software you can find on CD-ROM in device's package. Software has embedded step-by-step manual, which help set device's jumpers and adjust combining mode.

It is necessary to remember some features of device's operation in combining mode:

- output's settings (baudrate, stop-bits number, parity etc.) is identical to settings of input A;
- on input A it is necessary to connect NMEA 0183 source with highest baudrate to avoid input buffer overrun;
- jumpers' position is checked startup only. When you change jumpers' position you have to restart the device.
- don't forget often set jumpers to position providing necessary mode after configuring of device's combining mode.

7. Transportation and Storage

The device shall be stored in heated space at air temperature of +5 °C to +35 °C (maximum values of -55 °C to +70 °C), at relative humidity of air not exceeding 95 % at temperature of +25 °C and content of dust, oil, moisture and aggressive admixtures in the air not exceeding the norms envisaged by GOST 12.1.005-88 for the working zone of production areas.

The device shall be transported in transport container of the manufacturer in closed transport.

Means of transport:

- automobile and railway closed transport (covered wagons, universal containers)
- by air (in pressurized and heated bays of airplane)
- by sea (in dry service spaces).

The device shall be transported in accordance with the transport regulations in force for the particular transport.

During handling operations and transportations strictly observe the requirements of handling marks on boxes and do not allow bumps and impacts which can affect preservation and serviceability of the device.

Packed devices shall be reliably secured in vehicles.

After storage in stores or transportation at temperature below +10 °C the devices shall be unpacked only in heated spaces after keeping them unpacked in under normal climatic conditions for 12 hours.

8. Recycling

Do not recycle the packing of a new product, its parts with defects identified during its operation as well as the overage product as common household waste since they contain materials and raw materials suitable for their recovery.

Decommissioned and unused components should be delivered to a specialized waste collection center licensed by local authorities. You can also send the overage equipment to the manufacturer for its further recycling.

Proper recycling of the product components will prevent potential negative consequences for human health and the environment, as well as provide recovery of the product component materials while substantially saving on energy and resources.

The product does not endanger human life and health or the environment during and after its service life.

This product should be recycled following the requirements applicable to electronic equipment.



Products marked with a crossed-out recycle bin should be recycled apart from common household waste.

9. Warranty

The manufacturer guarantees the unit ADU-202 complies with this manual provided that the operation, transportation and storage conditions are adhered to during the warranty period.

The unit's warranty period expires 24 months from the date of its shipping from the manufacturer's storehouse.

Within the warranty period, the owner is entitled for a free repair, or a replacement of a separate part, provided that the malfunction occurred through the manufacturer's fault.

Warranty repair is provided if the unit is submitted with the manufacturer's label and a legible serial number available on it, as well as this operating manual.

The manufacturer is not responsible and cannot guarantee the unit's operation:

1. After the warranty period is over;
2. In case of the failure to observe the unit's operation, transportation, storage and installation rules and conditions;
3. If the unit is in an unmarketable condition, or has a damaged body, and other causes beyond the manufacturer's control;
4. If self-made electrical devices were used.
5. If there was an attempt to repair the unit by a person who is not an authorized representative of the manufacturer.

If the owner loses this operating manual or the manufacturer's label with a serial number, the manufacturer shall not provide their copies, and the owner shall be divested of the right for a free repair during the warranty period.

Upon the warranty expiry, the manufacturer shall facilitate the repair of the unit at the owner's expense.

Note: in case of warranty repair, the unit's disassembling from the installation site and its delivery to the manufacturer's service center are done at the owner's expense.

Visit the manufacturer's website www.unicont.spb.ru (section "support/warranty") to find:

- forms to fill in claims,
- full warranty description;
- full description of the warranty service rendering procedure.

The manufacturer service center's address and contact details:

Unicont SPb, Ltd.

Bld. 26E Kibalchich Str., Saint Petersburg, 192174, Russia

tel.: + 7 (812) 622 23 10, +7 (812) 622 23 11

fax: +7 (812) 362 76 36

e-mail: service@unicont.spb.ru

10. DATE OF PACKING

NMEA 0183 Amplifier-distributor Unit With
Integrated Combiner

ADU-202

№

name of article

designation

serial number

Packed Unicont SPb Ltd., Russia.
Manufacturer

according to the requirements of the current technical documentation.

post

signature

clarification of signature

year, month, day

11. ACCEPTANCE DETAILS

NMEA 0183 Amplifier-distributor Unit With
Integrated Combiner

ADU-202

№

name of article

designation

serial number

was manufactured and accepted in accordance with the regulatory requirements of the state standards and applicable technical documentation, and is suitable for operation.

Quality control representative

Stamp

here

signature

clarification of signature

year, month, day

12. DATE OF COMMISSIONING

NMEA 0183 Amplifier-distributor Unit With
Integrated Combiner

ADU-202

№

name of article

designation

serial number

The unit has been put into operation.

Date of installation: _____

Place of installation: _____

Person in charge of installation: _____