

**Unicont SPb Ltd**

**Digital Indicator  
DI-121**

Technical documentation

**Saint-Petersburg  
2008**

## Contents

1.	Purpose .....	3
2.	Delivery set.....	3
3.	Technical characteristics.....	3
4.	Principle of operation .....	3
5.	DI-121 set up (setting up procedure).....	3
5.1.	Switching to programming .....	3
5.2.	Settings description and purpose .....	6
5.2.1.	Interface RS-232/422/485 parameters .....	6
5.2.2.	NMEA 0183 sentence parameters .....	6
5.2.3.	Data display setting up .....	7
5.2.4.	Device calibration.....	7
6.	Installation and connection of device .....	8
7.	Warranty .....	9
8.	Sales data .....	10
9.	Acceptance data.....	10
10.	Commissioning certificate.....	10

## 1. Purpose

Device DI-121 is meant for displaying of received data in digitals from different signal sources with voltage output or digital messages NMEA 0183 format. Device can be produced for 1, 2 or 3 indicators. Each indicator has an input for signal receipt as direct voltage and input for NMEA 0183 message receipt.

## 2. Delivery set

- Digital indicator DI-121 1 pc
- CD with software for DI-121 configuration 1 pc

## 3. Technical characteristics

### Electric characteristics

Power supply voltage	9..36 VDC
Maximum power consumption	No more than 3 W
Galvanic isolation from power supply circuit	Yes
Protection from connection with reverse polarity power supply	Power supply polarity is not important

### Operating characteristics

<b>Operating characteristics</b> Weight	3 indicators – no more than 1 kg 2 indicators – no more than 0,7 kg 1 indicator – no more than 0,4 kg
Overall dimensions	3 indicators - 305 x 115 x 26 mm 2 indicators – 209 x 115 x 26 mm 1 indicator – 113 x 115 x 26 mm
Operating temperature	-25..+55 °C
Storage temperature	-55..+75 °C

### Input/output characteristics

Input of direct voltage measurement	Up to 30 VDC
Input NMEA 0183-sentences	1 x RS-232/422/485
Data receive rate	Up to 115200 bps
Inputs optoisolation	Yes

## 4. Principle of operation

Each indicator DI-121 displays data as received in NMEA messages as converted from voltage level of corresponding input. For proper data receipt in NMEA 0183 format it is required Input interface RS-232/422/485 setting. It is necessary to effect device calibration for proper conversion of voltage level to digitals. It can be done with help of software supplied together with DI-121.

## 5. Setting DI-121 (device setting procedure)

### 5.1. Switching to programming

For switching to programming remove back device case and set jumpers, see Fig.1.

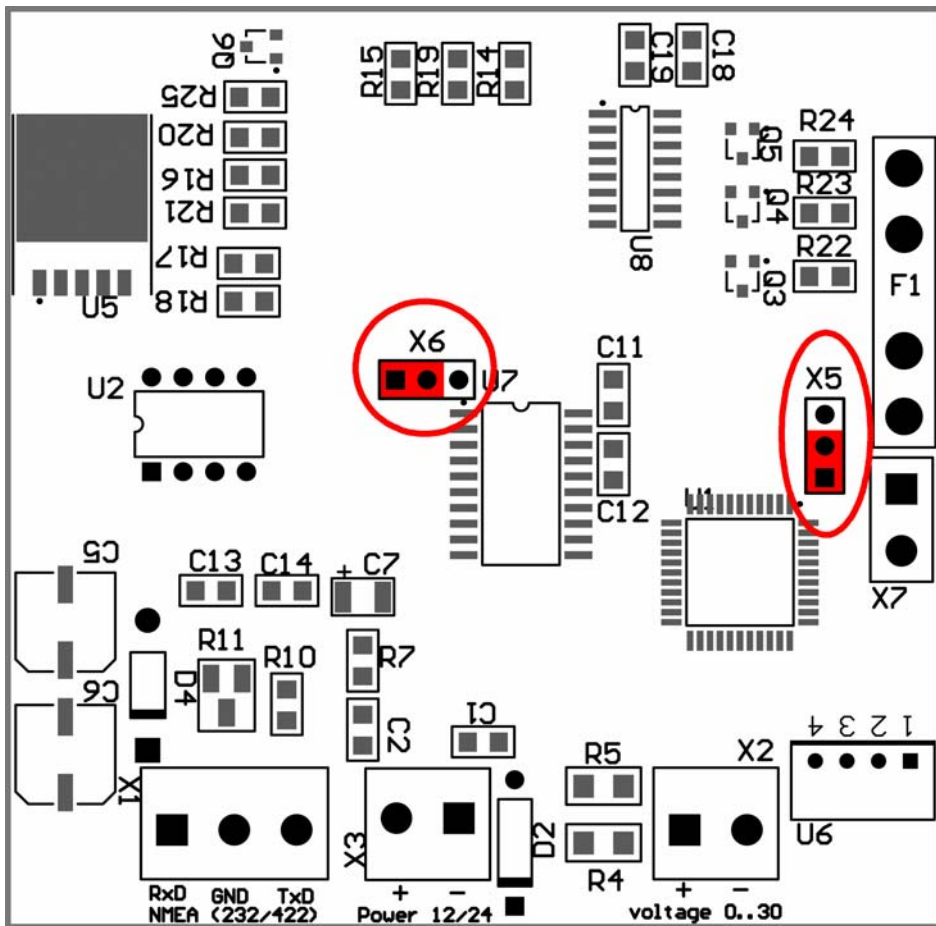

Fig.1. Jumpers setting on printed circuit board in programming regime.

Then it is recommended to perform device setting in the following sequence:

1. connect connector NMEA of DI-121 with COM-port of PC, power supply and signal source (in the form of direct voltage level), see Fig.2.
2. Load software for calibration of DI-121
3. Choose COM-port in software settings. If connection is done properly and chosen correct COM-port, green indicator “Connected” is alight in software window.
4. Press button “Download settings”.
5. Install required settings, calibrate device.
6. Press button “Upload settings” for record of settings in volatile memory of the device.

After settings and device calibration set up jumpers, see Fig.3, encase device back. Start installation of DI-121.

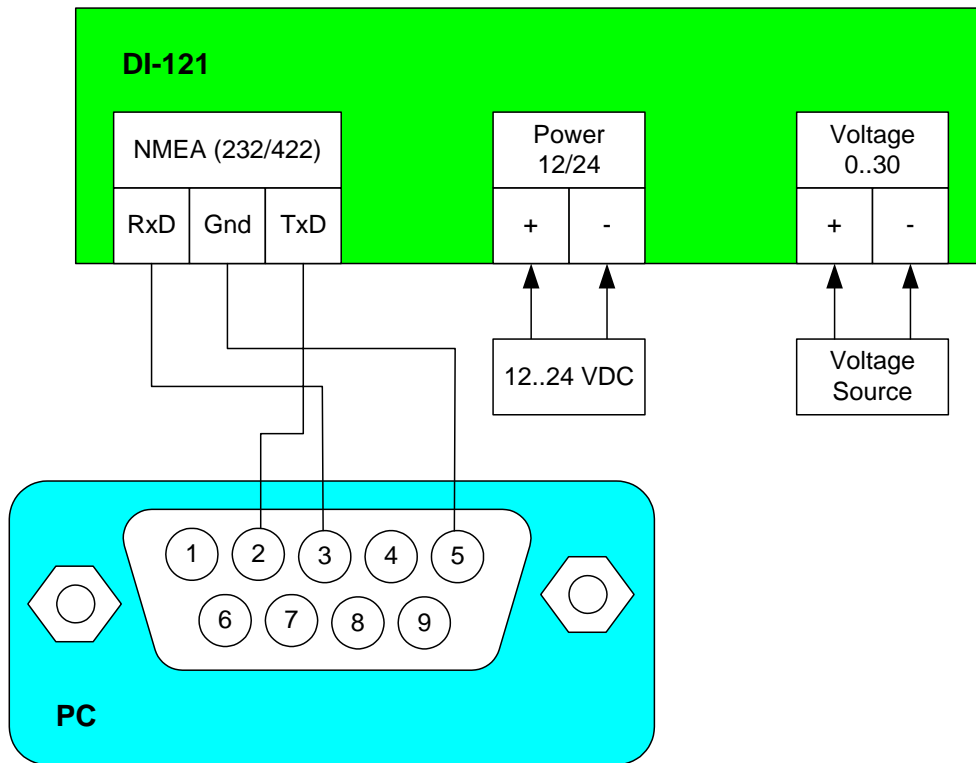

Fig. 2. Connection scheme of DI-121 for programming.

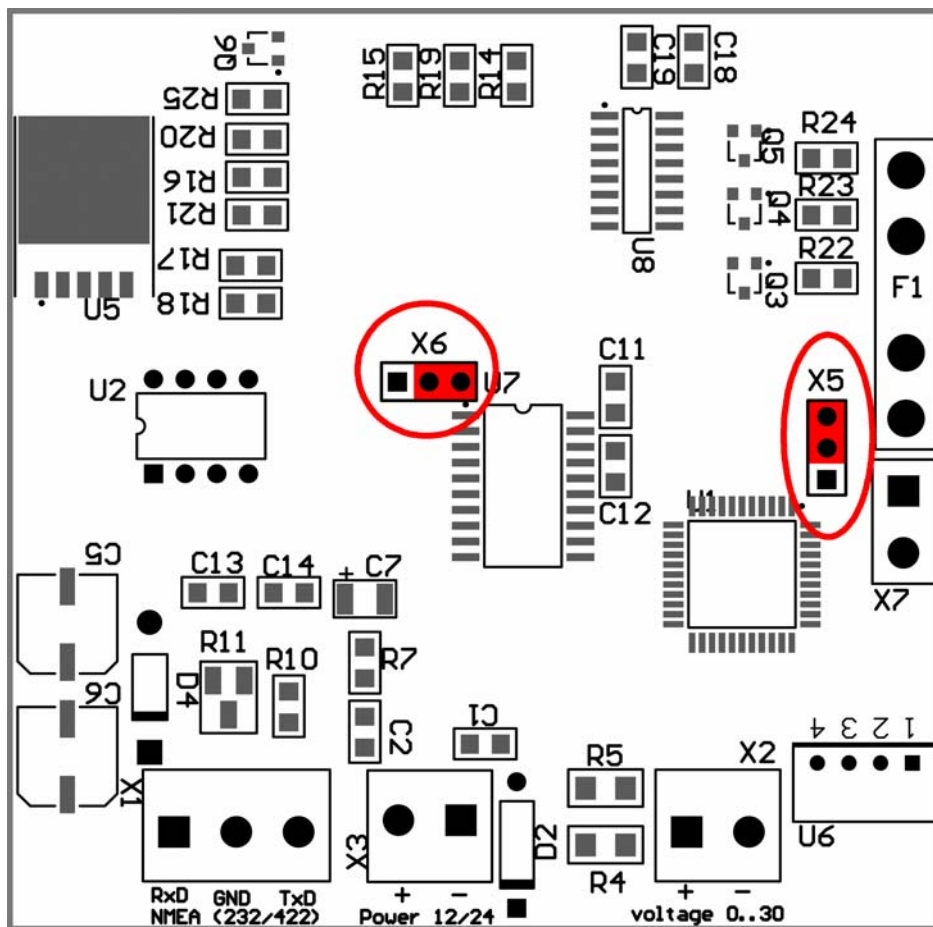

Fig. 3. Jumpers position on printed circuit board in operating regime.

## 5.2. Device settings description and purpose

DI-121 settings consist of the following groups:

- RS-232/422/485 Settings
- NMEA Settings
- Calibration
- Display Settings

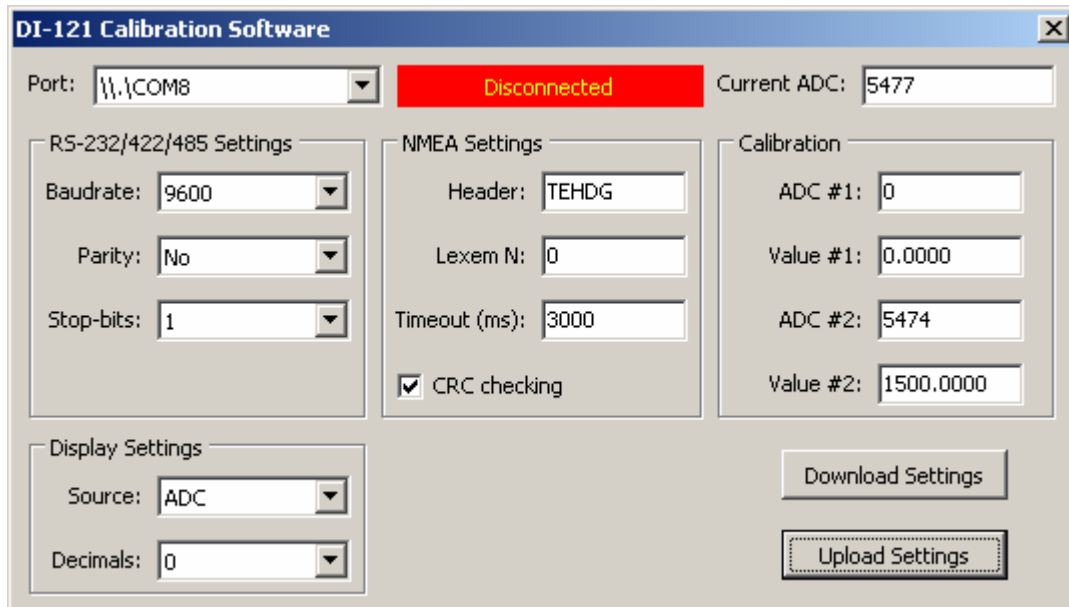

Fig. 4. Software window for calibration of DI-121.

### 5.2.1. Interface RS-232/422/485 parameters

#### Baud rate

Baud rate via serial interface RS-232/422.

Available values: 4800, 9600, 14400, 19200, 28800, 38400, 57600, 76800, 115200.

#### Parity

Parity check data received via serial interface RS-232/422.

Available values: No, Even, Odd

#### Stop-bits

Stop-bits number in bytes received via serial interface RS-232/422.

Available values: 1, 2

### 5.2.2. NMEA 0183 sentence parameters

#### Header

Header of NMEA sentence. Messages with headers different from the settled will be ignored by the device. Header length is 5 characters without spaces.

#### Lexeme No

Lexeme No. in sentence. Device can receive only digital lexemes. Symbols will be ignored by the device.

### Timeout (ms)

Timeout of NMEA data importation. If data importation stops for a period of time longer than specified by the user, device indicates «-----».

### CRC Checking

Checking of control sentence sum. DI-121 allows to effect checking of control NMEA 0183 sentence sum for ensuring channel noise-immunity. If control sum doesn't coincide with rating value sentence will be ignored by the device.

Sample of NMEA sentence:

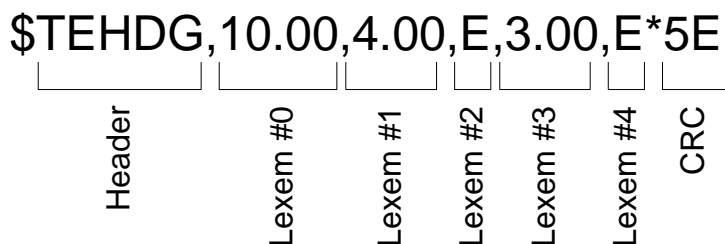

## 5.2.3. Display settings

### Source

Data source for indicating. ADC – value received by corresponding device input converted from voltage. NMEA – value received in NMEA 0183 format sentences.

Available values: ADC, NMEA

### Decimals

Maximum indicating values within corresponding settings:

Decimals	Minimum value	Maximum value
0	-999	9999
1	-99.9	999.9
2	-9.99	99.99
3	0.000	9.999
4	.0000	.9999

On exceeding of the abovementioned limits device displays «8.8.8.8.»

Available values: 0, 1, 2, 3, 4

## 5.2.4. Calibration

DI-121 voltage input is calibrated on 2 points (maximum and minimum value). Calibration is done in the following sequence:

1. supply minimum voltage to device input.
2. retype values from field «Current ADC» to «ADC #1».
3. record actual value (it is displayed with this voltage) to «Value #1».
4. supply maximum voltage (up to 30 V) to device input.
5. retype values from «Current ADC» to «ADC #2».
6. recode actual value (it is displayed) to «Value #2».

To save calibrations press «Upload Settings».

## 6. Installation and connection

It is recommended to perform device setting in the following sequence:

1. Choose the place for device installation, provide easy access, cables input and cable-ends splitting.
2. Prepare mounting holes for device installation. (See Fig.5)
3. Fix the device and screw it.
4. Connecting wires of power supply units and connected devices connect with terminal blocks and fix them with cable coupling at special mounting bracket.
5. Supply power to the device.
6. Do functional test of the device.

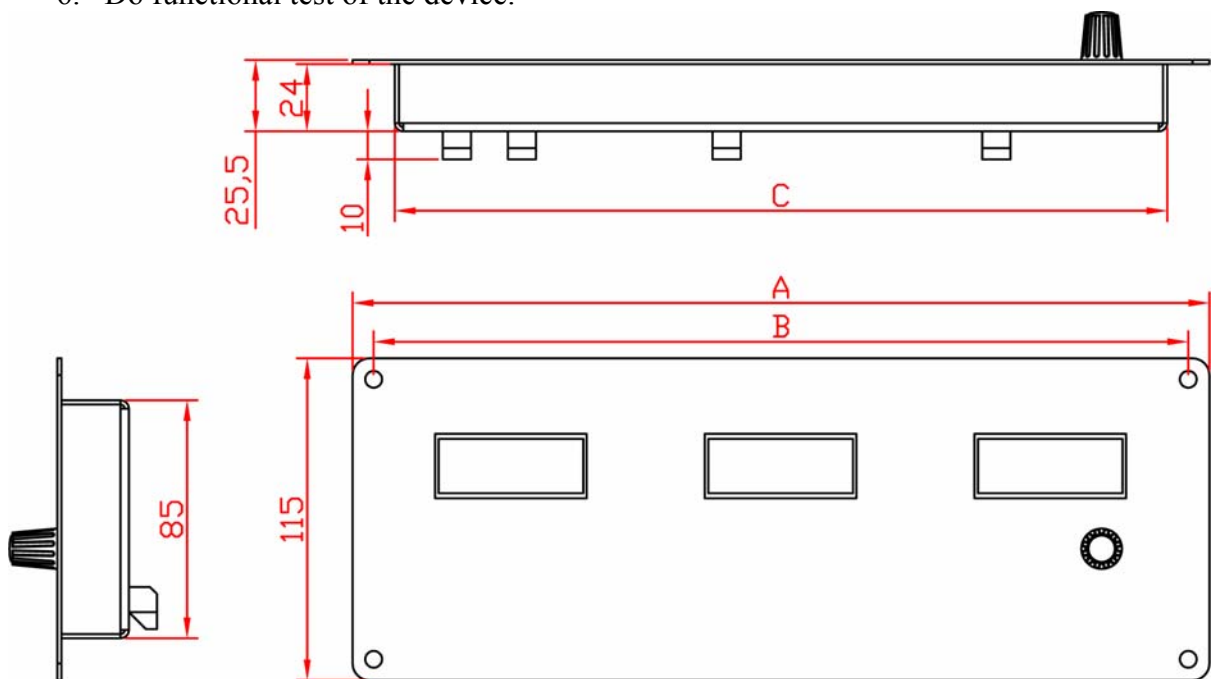

Fig. 5. Dimensional drawing.

Number of indicators	A (mm)	B (mm)	C (mm)
1	113	83	98
2	209	179	194
3	305	275	290



## 7. Warranty

The producer guarantees the conformity of the device DI-121 with the present technical manual in case of maintenance of operating, transportation and storage conditions during warranty period.

Warranty period terminates in 18 months from the sales moment or in 12 months from the date of device commissioning.

During the warranty period the device owner has the right for repair free of charge or for change of separate device block, if the malfunction appeared through producer's fault. Warranty repair is to be effected in case of presence of the operation manual and of data on acceptance and commissioning of the device stated in the manual.

The Producer is not responsible for and doesn't guarantee the workability of the device:

- 1) after expiration of the warranty period
- 2) in case of failure to maintain operating, transportation and storage terms for the device
- 3) in case of loss of the device commodity view or wholeness of the case and on other reasons not depending on the Producer
- 4) in case of use of self-made electric devices
- 5) if the device is repaired by a person, not being a representative person of the Producer

In case of failing to present the mark on commissioning the warranty period is to calculate from the sales date.

In case of failure to present this manual duplicate of data on acceptance and commissioning is not to be issued, and the owner loses the right for repair free of charge during the warranty period. After the expiry of warranty period the Producer assists in device maintenance at the expenses of the owner.

Note: in case of warranty repair device demounting and delivery of the device to the service-centre of the Producer is effected at the expenses of the device owner.

## 8. Sales data

Serial No. \_\_\_\_\_

Date of manufacture \_\_\_\_\_

Number of indicators \_\_\_\_\_

Supplier Unicont SPb Ltd.

Stamp here

## 9. Acceptance data

The device is produced and accepted in accordance with compulsory conditions of the government standards, present technical documentation and is recognized ready for operation.

Signature of the responsible person

\_\_\_\_\_

Stamp here

## 10. Commissioning certificate

Digital Indicator DI-121

Serial No. \_\_\_\_\_

Accepted for operation

Date \_\_\_\_\_

Place of installation \_\_\_\_\_

Installed by \_\_\_\_\_