

**Batteryless telephone system
with public address mode
BLTS-1006**

Operating manual

Table of contents

Introduction	4
TERMS AND ABBREVIATIONS.....	5
1 description and operation of the system	6
1.1 Description.....	6
1.2 Technical specifications	7
1.3 System composition.....	8
1.4 Structure and operation.....	12
1.5 Connection of the SC.....	14
1.6 Marking and sealing	15
1.7 Packaging.....	15
2 Description and operation of the system components.....	16
2.1 Description of the SC	16
2.2 Operation of the SC	21
3 Intended use	29
3.1 Operational limitations	29
3.2 Usage preparations	29
3.3 Use of the System.....	30
4 Technical service of the system.....	32
4.1 General description.....	32
4.2 Safety features	32
4.3 Maintenance routine	32
4.4 Instructions on SPTA kit	34
4.5 Preservation	34
5 Current repair.....	35
5.1 General description.....	35
5.2 Safety features	35
6 current repair of SC	36
6.1 Commutator telephones and telephones.....	36
6.2 Power supply units.....	37
6.3 Relay unit.....	38

7	Transportation and storage	39
8	Disposal	40
	Appendix A SPTA kit list	41
	Appendix B Description of the SC.....	42
	Appendix C Set of operation and maintenance documents	64
	Appendix D Settings of SC	65
	Appendix E Connection of the SC	68
	Appendix F The scope of delivery	72

INTRODUCTION

This Operating manual describes equipment of Battery less telephone system BLTS-1006 (modernized) (hereinafter referred to as the System).

This operating manual (hereinafter – OM) describes composition, structure, specifications, System components (hereinafter – SC) and instructions to ensure correct and safe operation of the System (intended use, technical service, current repair, storage and transportation), as well as information on System components disposal.

Only those who have read and understood this document and those who have had special training shall be permitted to operate the System according to the applicable regulations. In addition to the instructions given in this document, the safety regulations and rules applicable in the field shall be observed.

This OM covers any System configurations.

The System may be scaled for any object due to different models of communication devices and scheme of user network design.

TERMS AND ABBREVIATIONS

ACB	Automatic circuit breaker
AP	Amplifier and pre-amplifier of voice signals of external communication devices
BT	Battery less telephone
BTC	Battery less telephone communication
CB	Call button
CL	Check list
CUESU	Control unit for external signaling units
EG	Electric generator
ES	Energy storage
LCD	Liquid crystal display
LIO	LED «Inductor on»
MTH	Microtelephone headset
OD	Operational documentation
OM	Operating manual
PA	Public address
PSU	Power supply unit
RMRS	Russian Maritime Register of Shipping
RRR	Russian River Register
SC	Signal converter
SPTA	Spare parts, tools and accessories
SUIC	Signaling unit of incoming call
TS	Technical service
USU	User selection unit
VC1	Voltage converter №1
VC2	Voltage converter №2

1 DESCRIPTION AND OPERATION OF THE SYSTEM

1.1 Description

1.1.1 The System is designed to provide telephone communication both in routine operation (if power is available or unavailable) and emergencies caused by failure (or de-energization) of shipborne communication systems.

1.1.2 The SC may be installed in indoor spaces and on open deck.

1.1.3. The SC maintain operation under the following conditions:

a) operating temperature range:

– minus 15 °C...plus 55 °C – for the SC installed indoors;

– minus 40 °C...plus 55 °C – for the SC installed on open deck;

b) increased air humidity 100 % at temperature plus 50 °C;

c) inusoidal vibration within frequency range 1...200 Hz at the following oscillation amplitudes:

– amplitude ± 1 mm – for frequency range 2.0...13.2 Hz;

– acceleration 0.7g (7 m/sec²) – for frequency range 13.2...100.0 Hz;

d) mechanical impacts (multiple), length 10...15 ms and max. acceleration 70 m/sec² (7g);

e) roll and pitch with amplitude $\pm 45^\circ$ and period 7...9 sec;

f) tilting angle 45° during 5 minutes;

g) electromagnetic and magnetic interference;

h) ingress of water, atmospheric precipitation (for the SC of splash proof type).

1.1.3 The SC maintain operation under the effect of:

a) limiting temperature minus 60 °C...plus 70 °C;

b) salt (sea) fog.

1.1.4 The System is designed considering the following documents:

– Rules of Russian Maritime Register of Shipping;

– Rules of Russian River Register;

– Technical regulations on security of the marine transport;

– Technical regulations on security of the inland water transport.

1.2 Technical specifications

The System ensures:

- a) application of BTC user network using several two- or three-wire channels and PSU (or without PSU);
- b) user may initiate and accept a call, hold communication session in BTC user network with / without connection to power mains;
- c) operation from an inductor (manual generator) or external PSU in the following modes:
 - pair communication – between two users;
 - general list (all) or selective conference call – between all or selected users (max. 25 users);
- d) communication session (for pair communication) with min. length 10 minutes – after one rotation cycle of generator (max. speed 3 rot/sec during 3...5 sec) or more, if an inductor handle was rotated for the second time;
- e) possibility to hold communication:
 - in individual means of respiratory protection (using external communication devices with throat microphones);
 - in environment with increased level of noise (max. 130 dB) – using individual means of hearing protection (headset or intercom helmet);
- f) telephone communication up to 20 m due to extended cord of communication device (headset or intercom helmet);
- g) telephones and commutator telephones provide for intermittent sound and light signaling of outgoing call. Commutator telephones additionally provide for light signaling of selected user line;
- h) telephones and commutator telephones provide for flashing sound and light signaling of incoming call. Commutator telephones additionally provide for light indication of calling user;
- i) external call signaling units may be connected to telephones and commutator telephones (except commutator telephone PH2-5C-PO); they may repeat incoming call signaling (if power supply is available) and reset current alarm as well;
- j) electric generator status (inductor) and power supply is controlled by constant LED glowing.

The System may operate from the power mains and in autonomous mode (without connection to the power mains).

Energy produced by generator rotation is stored by high capacity condensers integrated in telephones and commutator telephones.

The System may be connected to power mains 24 (18...36) V DC (if required).

The System is connected to AC power mains via the System PSUs – PS-103, PS-103-20.

Signaling units are powered from external DC network 24 V or AC network, 50 (60) Hz, voltage 220 V.

In case of power failure, the System automatically switches to inductor power, not interrupting current connection.

The System includes metal cabinet for installation on open deck, protecting equipment against water.

1.3 System composition

1.3.1 Structure of BTC system is shown in Figure 1.

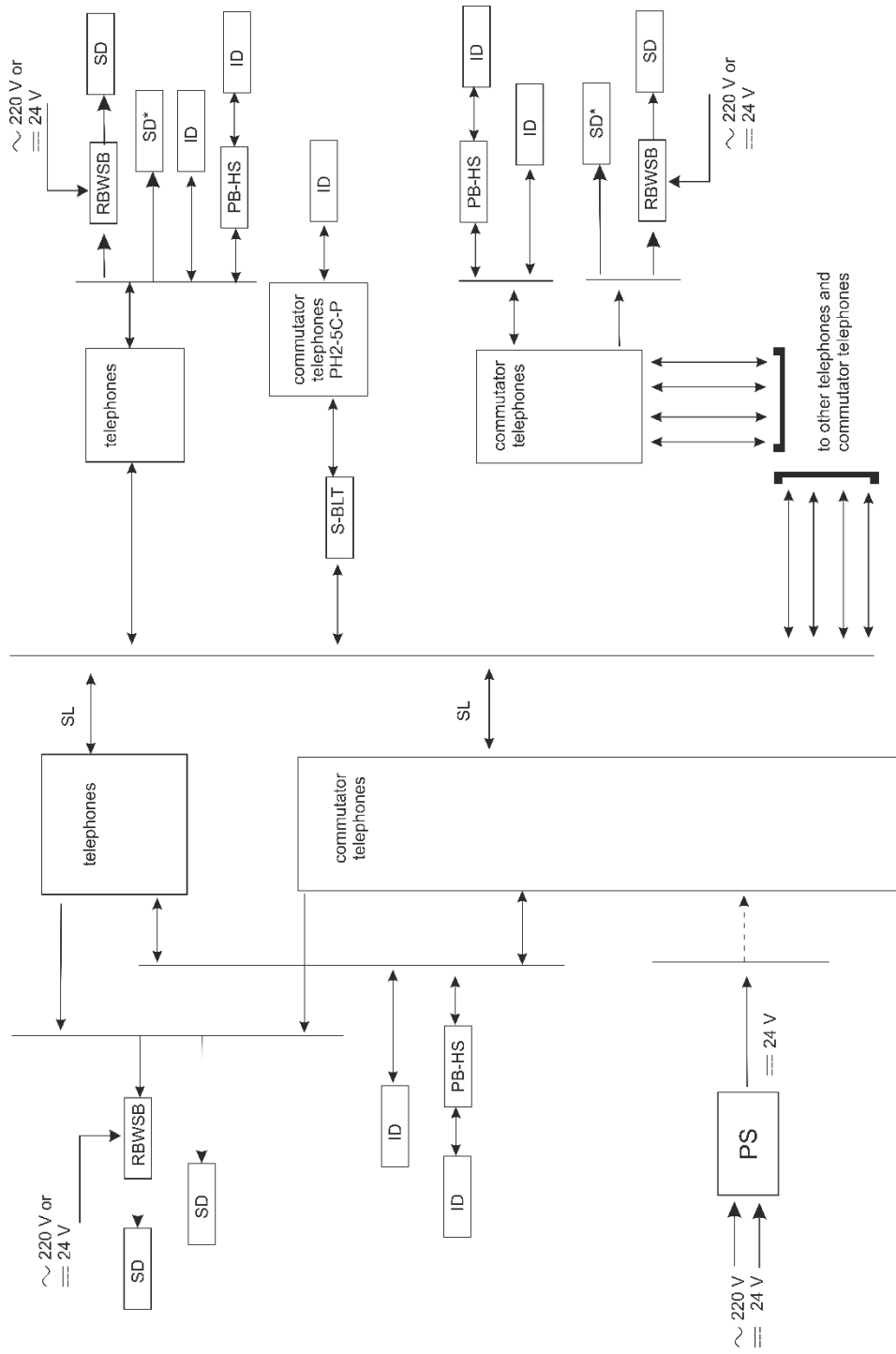

ID - External interphone devices (HS, TH)
SD - External signalling devices (RL, L, A, AL)
PS - Power supply units (PS-103, PS-103-20)
RBWSB - Relay unit
S-BLT - Socket for portable commutator telephones
PB-HS - Socket for ID
SL - number of subscriber lines

SD* - SD can be connected directly to telephones and commutator telephones (without RBWSB; \approx 24 V)

Figure 1 – BTC user network

1.3.2 The System includes:

- a) commutator telephones:
 - stationary, wall or panel mounted for 5, 15, 20 and 25 lines of pair communication;
 - portable for 5 lines of pair communication;
- b) telephones, panel and wall mounted types;
- c) flashing lamps and light, sound, and light-sound signaling units, and relay unit RBWSB type;
- d) external communication devices – headsets or intercom helmets;
- e) power supply units – PS-103 with power 190 W and PS-103-20 with power 400 W;
- f) cords CE type and sockets PB-HS, S-BLT types;
- g) cabinet for mounting on open deck BLTS-BO type to protect the SC against marine atmosphere.

For the list of SC, see Table 1.

Table 1 – The list of System components

SC name	Code	Installation conditions
Telephones	PH2-1W	For outside open spaces, special spaces, bridge, central control stations and accommodation areas. IP56
	PH2-1P	
Commutator telephone	PH2-5C-W	For outside open spaces, special spaces, bridge, central control stations and accommodation areas. IP56
	PH2-10C-W	
	PH2-15C-W	
	PH2-20C-W	
	PH2-25C-W	For outside open spaces, special spaces, bridge, central control stations and accommodation areas. IP56
	PH2-5C-P	
	PH2-10C-P	
	PH2-15C-P	
	PH2-20C-P	
	PH2-25C-P	
Portable commutator telephone	PH2-5C-PO	For outside open spaces, special spaces, bridge, central control stations and accommodation areas. IP56
Relay unit	RBWSB-24	For outside open spaces, special spaces, bridge, central control stations and accommodation areas. IP56
	RBWSB-220	

SC name	Code	Installation conditions
PSU	PS-103	For special spaces, bridge, central control stations and accommodation areas. IP22
	PS-103-20	
Intercom helmet	TH-4M-S	For outside open spaces, special spaces, bridge, central control stations and accommodation areas. IP56
	TH-4M-W	
	TH-4M-S-C	
	TH-4M-W-C	
	TH-4M-S-AC	
	TH-4M-W-AC	
	TH-4L-S	
	TH-4L-W	
	TH-4L-S-C	
	TH-4L-W-C	
	TH-4L-S-AC	
	TH-4L-W-AC	
Headset	HS-3	For outside open spaces, special spaces, bridge, central control stations and accommodation areas. IP56
	HS-3P	
	HS-5	
	HS-5C	
	HS-5AC	
Socket	PB-HS	For outside open spaces, special spaces, bridge, central control stations and accommodation areas. IP56
	S-BLT	
Sound-light signaling unit	AL-24-R	For outside open spaces, special spaces, bridge, central control stations and accommodation areas. IP56
	AL-24-O	
	AL-24-W	
	AL-24-G	
	AL-24-B	
	AL-220-R	For outside open spaces, special spaces, bridge, central control stations and accommodation areas. IP56
	AL-220-O	
	AL-220-W	
	AL-220-G	
	AL-220-B	
Sound signaling unit	A-220	For outside open spaces, special spaces, bridge, central control stations and accommodation areas. IP56
	A-24	
Light signaling unit	L-24-R	For outside open spaces, special spaces, bridge, central control stations and accommodation areas. IP56
	L-24-O	
	L-24-W	
	L-24-G	

SC name	Code	Installation conditions
	L-24-B	For outside open spaces, special spaces, bridge, central control stations and accommodation areas. IP56
	L-220-R	
	L-220-O	
	L-220-W	
	L-220-G	
	L-220-B	
Flashing light	RL-24-O	For outside open spaces, special spaces, bridge, central control stations and accommodation areas. IP56
	RL-24-B	
	RL-24-R	
	RL-24-G	
	RL-220-O	For outside open spaces, special spaces, bridge, central control stations and accommodation areas. IP56
	RL-220-B	
	RL-220-R	
	RL-220-G	
Cabinet	BTS2-BO	For outside open spaces, special spaces, bridge, central control stations and accommodation areas. IP56
Cord	CE-1.5	For outside open spaces, special spaces, bridge, central control stations and accommodation areas. IP56
	CE-3	
	CE-5	
	CE-7	
	CE-10	For outside open spaces, special spaces, bridge, central control stations and accommodation areas. IP56
	CE-1.5BE	
	CE-3BE	
	CE-5BE	
	CE-7BE	For outside open spaces, special spaces, bridge, central control stations and accommodation areas. IP56
	CE-10BE	
	CE-1.5AC	
	CE-3AC	
	CE-5AC	For outside open spaces, special spaces, bridge, central control stations and accommodation areas. IP56
	CE-7AC	
CE-10AC		

1.4 Structure and operation

1.4.1 Structure and composition of the SC allows for application of shipborne and manual BTC systems with various structure, functionality and user capacities.

The System ensures the following networking types:

a) pair communication (one line), see Figure 2;

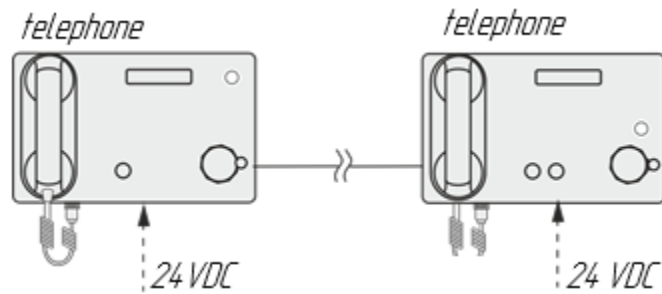

Figure 2 – Pair communication

b) communication between the main station and user group (several lines) using commutator telephones and telephones for pair communication and general list (all), see Figure 3;

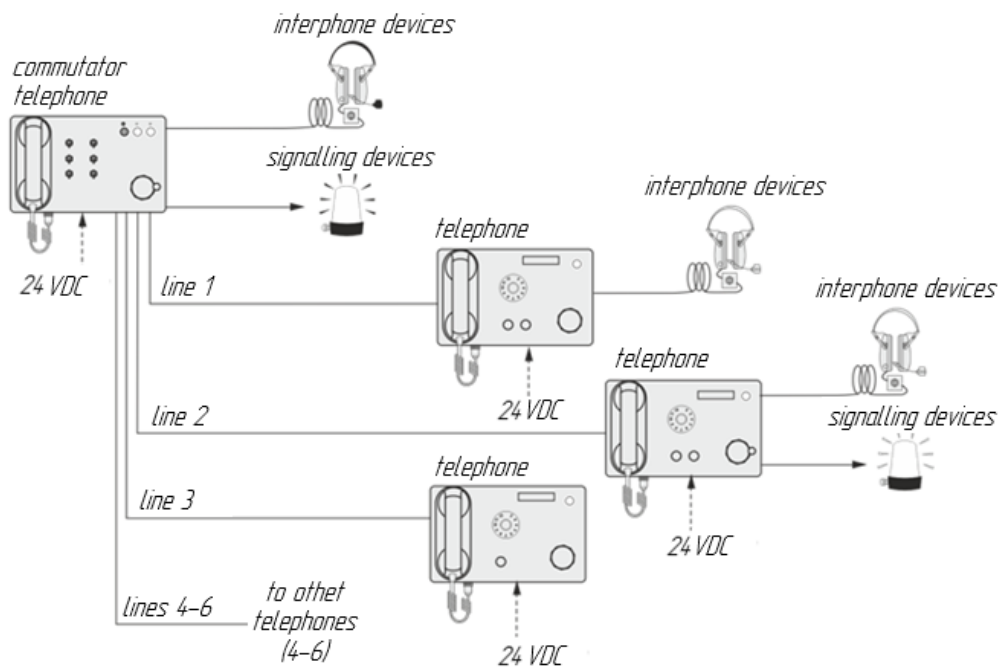

Figure 3 – Network based on commutator telephones and telephones

c) combined user network (using any combination of commutator telephones and telephones) for communication (pair and general list (all)) of the main station within its group and users of other groups, see Figure 4.

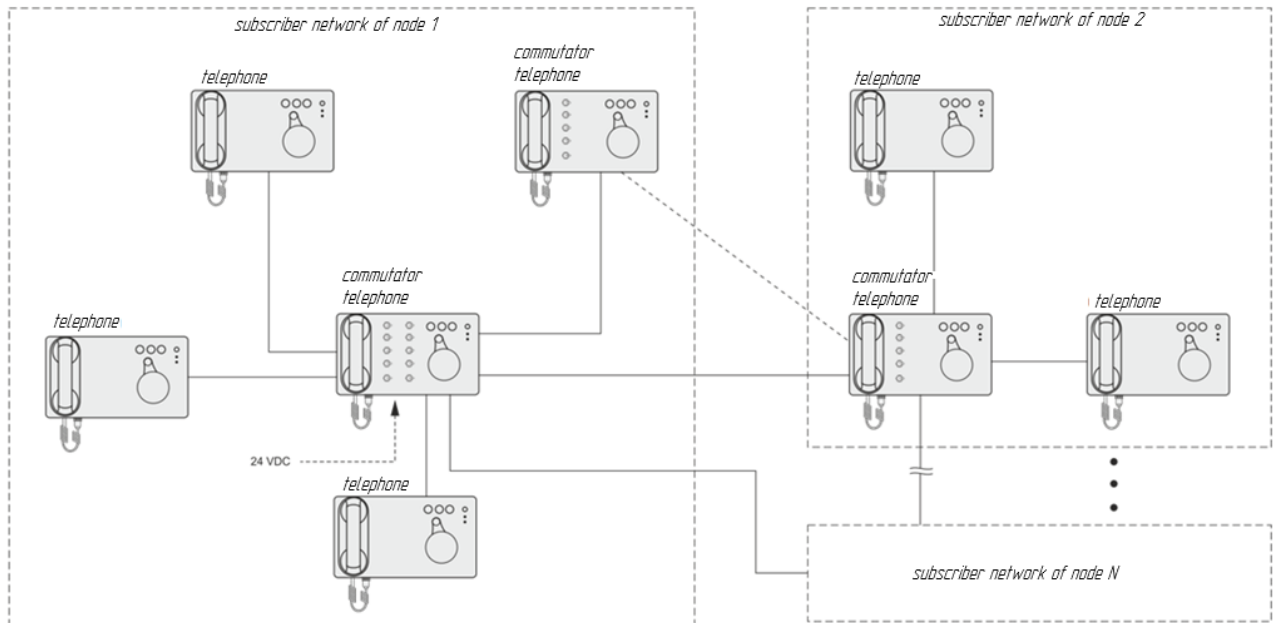

Figure 4 – Combined user network

Connection of the SC is carried out directly at Customer facilities.

1.4.2 The System operates in two modes:

a) BTC mode – applied in case of power mains failure; the System users are powered from inductor (manual electric generator), which is integrated into telephones (commutator telephones). The System operation in this mode is not limited by time, all functions (see 1.2) will be available; external signaling units (if any) may operate or be disconnected depending on power availability;

b) PA mode – applied in case of available power mains; the System users are powered from external power source. Telephones and commutator telephones in this mode operate as regular PA devices; a call is initiated by corresponding button; telephone communication in the user network is carried out from external PSU and do not require manual generator.

1.5 Connection of the SC

Connect SC according to the connection diagrams designed (if required) in compliance with technical requirements for particular object and delivered to enterprise designer (or Customer), if it was stipulated in Supply contract.

Examples of connection diagrams are represented on the Manufacturer's website (www.unicont.com) in section *Shipborne electronics*.

1.6 Marking and sealing

All SC have nameplates indicating a name of SC, identifier, serial number, weight, nominal values of main parameters and Manufacturer's name.

Commutator telephones are delivered with names of user line switches; the names are produced using laser printer and photograph paper, inserted into transparent film pockets under a single toggle switch or group of toggle switches (depending on the model), using bold face «Arial», size 14. All centres of legends are shifted for 2.5 mm to the right for convenient use (reading).

Note – single-channel telephones do not have user line switches, but they have a name of user line.

Electric installation organization has a right to open the SC for installation at Customer facilities for further lead and assignment of cables.

Delivered SC are not sealed by the Manufacturer.

1.7 Packaging

The SC are delivered, transported and stored in packaging and inner packaging.

Transport packaging is also used as a returnable packaging for transportation of the SC to the repair location and back.

2 DESCRIPTION AND OPERATION OF THE SYSTEM COMPONENTS

2.1 Description of the SC

2.1.1 Commutator telephones

The System includes three types of commutator telephones:

- wall mounted PH2-xC-W (where x – 5, 10, 15, 20 or 25);
- panel mounted PH2-xC-P (where x – 5, 10, 15, 20 or 25);
- portable PH2-5C-PO.

Portable commutator telephone PH2-5C-PO type ensures connection (via socket S-BLT) to user network and pair or group communication (max. 5) with System users in pair or general list (all) modes.

Other types provide for user networks with capacity 5, 10, 15, 20, 25 lines for pair and group communication with users of their own network in pair and general list (all) modes.

Use toggle-switches to select users of the assigned lines.

All commutator telephones are equipped with a telephone receiver (corded) to provide for two-way communication with other users.

External communication devices (headsets and intercom helmets) may be connected to all commutator telephones directly or using socket PB-HS type. Connections of external communication devices are shown in Figure 5.

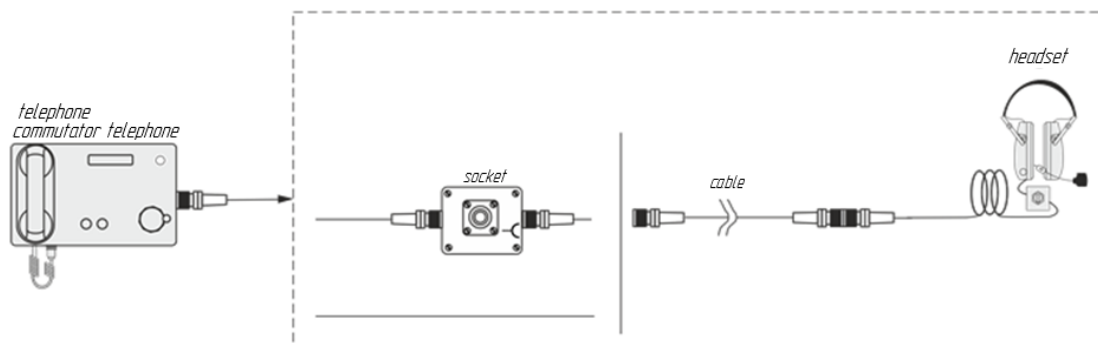

Figure 5 – Connections of external communication devices to telephones (commutator telephones)

All commutator telephones, except portable PH2-5C-PO, ensure control (according to scheme – electric circuit switch) over external signaling units and repeat (if necessary) incoming call with light and (or) sound signaling.

Connections of external signaling units are shown in Figure 6.

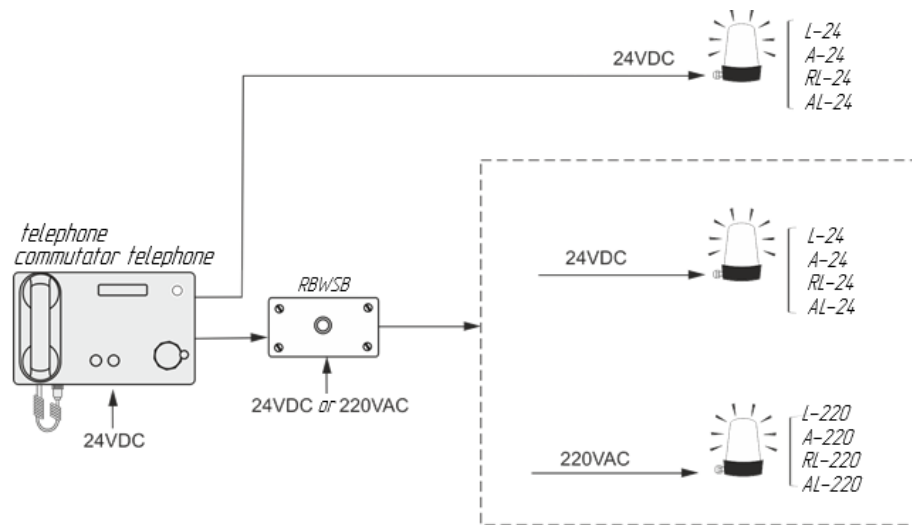

Figure 6 – Connections of external signaling units to telephones (commutator telephones)

All commutator telephones have LED light indicator of power status when power is supplied from the power source.

All commutator telephones have controls backlight which switches on automatically once the power is supplied from external source.

Use commutator telephones on open deck only mounted in cabinet BLTS2-BO.

2.1.2 Telephone units

Telephones PH2-1 type provide for pair communication (in combination commutator telephone-telephone or telephone-telephone) in BTC network (two-wire line or three-wire line).

The System includes two types of telephones:

- wall mounted PH2-1-W;
- panel mounted PH2-1-P.

All telephones are equipped with telephone receiver for two-way communication with other users.

External communication devices (headsets and intercom helmets) may be connected to all telephones directly or using socket PB-HS type. Connections of external communication devices are shown in Figure 5.

All telephones ensure control (according to scheme – electric circuit switch) over external signaling units and repeat (if necessary) incoming call with light and (or) sound signaling. Connections of signaling units are shown in Figure 6.

Signaling units (to repeat incoming call signaling) shall be powered from the power mains.

All telephones have LED light indicator of power status when power is supplied from the power source.

All telephones have controls backlight which switches on automatically once the power is supplied from external source.

Use telephones on open deck only mounted in cabinet BLTS2-BO.

2.1.3 External communication devices

Communication devices ensure freedom to move around workplace, as well hearing protection against increased noise (decreasing level of acoustic disturbance due to people's work and surrounding mechanisms). The System includes helmets with throat microphones allowing for communication in means of respiratory protection.

The System includes the following external communication devices:

- headsets;
- microphone-telephone intercom helmets, summer and winter types;
- throat microphone-telephone intercom helmets, summer and winter types.

Headsets are based on steel headband and may be adjusted individually for convenient use. Headsets are equipped with noise-protected microphone for operation in noisy environment.

Intercom helmets are used in conditions of increased noise to protect user's hearing organ. They are equipped with microphones having low noise sensitivity or throat microphones.

The System's intercom helmets are produced in three sizes: I, II or III. Specify a required size at order.

Headsets and intercom helmets ensure two-way communication when connected to commutator telephones and telephones.

Headsets and intercom helmets are equipped with switching device PTT type that connects / disconnects the device and commutator telephone (telephone).

Cables of headsets and intercom helmets with character «P» in code (identifier) are equipped with waterproof connector for telephones (commutator telephones) or socket PB-HS type.

Headset or intercom helmet may be connected directly (using corresponding connectors or terminal block), or using external junction boxes and sockets PB-HS type, see Figure 5. The cord CE type may be extended up to 20 m.

2.1.4 External signaling units

Signaling units ensure light, sound or sound-light signaling of incoming call on telephone (commutator telephone).

The System includes the following signaling units:

- a) sound signaling unit type A with sound high tone signaling;
- b) light signaling unit type L and RL with light impulse and flashing signaling;
- c) sound and light signaling unit AL type with light impulse and sound high tone signaling;

d) relay unit type RBWSB that switches voltage to signaling units power circuits by control signals from telephone (commutator telephone). It ensures call signaling in the following modes (configure at installation):

- synchronous – call signaling lasts as long as incoming call;
- with delay – call signaling will last 10 seconds after the call is finished;
- continuous – call signaling lasts unless «Reset call» button is pressed on telephone, commutator telephone or relay unit.

Relay unit is equipped with «Reset call» button to switch off (manually) the signaling in delay or continuous modes.

Signaling units installed on telephone stations shall be powered from power mains with rated voltage 24 V DC or 220 V AC, frequency 50 (60) Hz.

Signaling units A-24, AL-24, L-24, RL-24 types operate with power mains 24 V and may be connected to telephones (commutator telephones) directly and using relay unit.

Signaling units A-220, AL-220, L-220, RL-220 types operate with power mains 220 V and shall be connected to telephones (commutator telephones) only using relay unit.

2.1.5 Sockets

Sockets PB-HS type ensure connection of communication devices to telephone (commutator telephone). Socket has a waterproof connector and protective cover for connector.

The System also includes PB-HS type socket to connect an audio recorder to telephone (commutator telephone).

Sockets S-BLT-24 type connects portable telephone PH2-5C-PO to user network; it is equipped with cover to protect a connector against water ingress while carrying disconnected portable telephone.

2.1.6 Power supply units

Power supply units PS-103 and PS-103-20 ensure power supply of the SC from AC power mains with 50 (60) Hz and rated voltage 110 V or 220 V. PSUs ensure automatic load switching to standby power in case of main power failure.

2.1.7 Metal cabinet

Metal cabinet protects the SC installed on open deck against atmospheric precipitation, water, wind, low temperature and accidental mechanical damage; it may also house peripheral equipment and SC when they are not used.

The System includes BLTS2-BO cabinet to house any telephone or commutator telephone.

Cabinet door has max. opening angle 105° and may be fixed in open position. It also has a door stopper.

2.1.8 Cords

Cords extend cables of external communication devices.

Cords CE types are equipped with two waterproof connectors; Cords CE types with «AC» characters in code (identifier) have waterproof connector on one side, and angle connector – on other side; Cords CE types with «BE» characters in code (identifier) have waterproof connector on one side, and bare crimped ends – on other side.

The System includes cords 1.5; 3.0; 5.0; 7.0 and 10.0 meters.

2.2 Operation of the SC

2.2.1 Commutator telephones

The System’s commutator telephones are manufactured in metal painted steel casings. The units are wall and panel mounted for installation in dry and humid premises. Use metal cabinet BLTS2-BO to install units on open deck. Commutator telephones are applied for talk-back communication with BTC users.

All commutator telephones (except portable one) are delivered with telephone receiver PH-1, portable commutator telephone – with PH-3. It is equipped with a PTT to connect to commutator telephone. The receiver is placed in commutator telephone holder.

Controls of commutator telephones are represented in Table 2.

Table 2 – Description of commutator telephones and telephones controls

Control element	Description	SC
«Call» button	To initiate a call (if power mains available)	Commutator telephones and telephones
«Reset call» button	To reset incoming call signal	Commutator telephones, telephones and relay unit
Inductor handle	To generate energy (during rotation) required to initiate a call and to power commutator telephones and telephones of the System during current connection	Commutator telephones and telephones
Brightness dimmer	To adjust (if power mains available) backlight brightness of controls	Commutator telephones and telephones
Toggle-switch to select user line	To connect to the selected user line	Commutator telephones
Telephone receiver PTT switch	To connect microphone and speaker of telephone receiver to user unit	Commutator telephones and telephones

LED light indicators of commutator telephones and telephones are represented in Table 3.

Table 3 – Description of commutator telephones and telephones LED light indicators

Control element	Description	SC
«Call»	1 Light signaling of incoming call 2 Light signaling of outgoing call	Commutator telephones and telephones
«Power»	Indication of external power supply	Commutator telephones and telephones
«Inductor on»	Light indication of inductor operation status (while rotated)	Commutator telephones and telephones
«User»	1 Light indication of the selected user line 2 Light indication of calling user line number	Commutator telephones

Generally, a commutator telephone consists of:

- USU (with toggle-switches and LEDs);
- built-in PSU;
- SUIC;
- CUESU;
- «Inductor on» LED;
- CB;
- ES;
- VC1 and VC2;
- SC (provides for mixing and distribution of power voltage and voice signal);
- communication device, telephone receiver, headset and intercom helmet;
- AP and EG (inductor).

For the functional diagram of commutator telephone, see Figure 7.

Rotation of EG creates voltage which switches on LIO; then the voltage is supplied to VC1 and VC2, and then to AP and ES, and to USU as well; at the same time, generated block signal of external signaling units actuation is then supplied to CUESU.

Once user line toggle is switched on at USU, energy produced by inductor initiates a call to SUIC, and, at the same time, to user line, actuating call signaling.

Operation of commutator telephone from external network via built-in PSU fully repeats operation from inductor (the latter is not used), but energy is supplied to USU and CUESU only after pressing CB.

Transmission of voice signals to user and back is provided by AP and SC, once PTT is pressed on the corresponding device.

Energy received by user line during incoming call is supplied to SUIC and CUESU, and then actuates incoming call signaling; at the same time, it is supplied to USU and switches on light signaling of user line.

Once user line toggle switch is actuated on USU, energy from user line is supplied to inputs VC1 and VC2; then power is supplied to AP and ES. AP and SC ensure transmission of voice signals to user and back after pressing a PTT switch on the corresponding communication device.

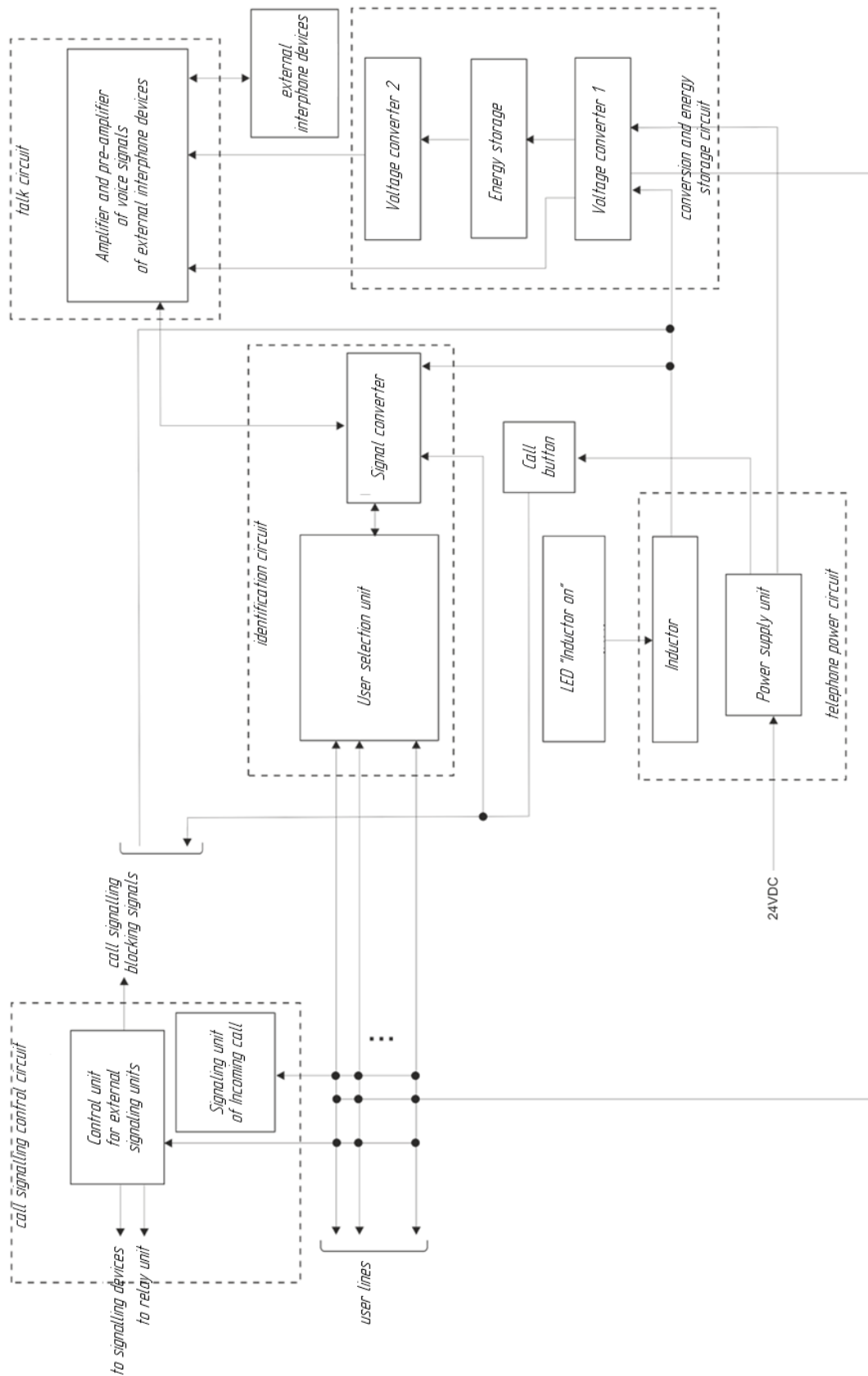

Figure 7 – Functional diagram of commutator telephone

2.2.2 Telephones

The System telephones PH2-1 type are modifications of commutator telephone PH2-10C; they have the same construction, see LEDs and controls (except USU), and functional diagram in Table 2 and Figure 7.

2.2.3 Sockets

The System sockets are wall mounted, waterproof type, equipped with protective cover, providing air-tight protection of connector's contact parts against water; may be installed on open deck.

Sockets are manufactured in metal painted casings. From the front side they have a quick connector with waterproof cover. Cable glands are also located on the casings.

2.2.4 External alarm units

2.2.4.1 Signaling units

All units are waterproof and may be installed on open deck. Signaling units are wall mounted, or may be mounted on a bracket (any orientation).

Signaling units are powered from external network with telephone (commutator telephone) connected in series with signaling unit (in a line break), or relay unit RBWSB.

During incoming call, telephone (commutator telephone) independently actuates signaling unit by CUESU signal or via relay unit RBWSB closing its circuit.

Signaling units L, AL, A types are produced in plastic impact-resistant casings. Casings (from four sides) have special knock-out type plugs, providing for cable lead in the most convenient place.

Signaling units AL and A types have integrated sound generator and regulator module of sound pressure level providing for regulation within 30...105 dB.

Signaling units L and AL types are equipped with xenon lamp operating in impulse mode with frequency 60...90 impulses per minute.

Flashing lamps RL type are produced in plastic transparent globe (specify colour at delivery), mounted in metal foundation. Incandescent lamp 40 W is placed inside – for RL-220, or halogen 70 W – for RL-24, as well as mechanism with plastic mirror reflector and motor. Once power is supplied, the lamp starts continuous glowing; mechanism starts rotating mirror reflector around the lamp resulting in flashing mode.

Table 4 – Colours of globe types

Signaling unit type	Globe colour				
	Red	Orange	White (transparent)	Green	Blue
RL	+	+	-	+	+
AL	+	+	+	+	+
L	+	+	+	+	+
«+» - colour is available. «-» - colour is not available.					

2.2.4.2 Relay unit

Relay unit RBWSB type is manufactured in impact-resistant plastic casing, wall mounted; may be installed on open deck. Received control signal actuates contacts which close input power circuits (220 V – for RBWSB-220, or 24 V – for RBWSB-24) on signaling unit circuit.

Cables are led through cable glands. Relay unit is equipped with call reset button, call LED, and three parallel ports to connect signaling units and ensure signaling in three modes (2.1.4). Settings of call mode are carried out using jumpers JP1 and JP2 on the device board according to Table 5.

Table 5 – Settings of relay unit modes

Jumper	Set / not set	Function
JP1	set	call signaling lasts unless «Reset call» button is pressed
JP2	set	call signaling lasts for 10 sec after call is finished
JP1, JP2	not set	call signaling lasts unless calling user finishes the call
JP1, JP2	set	call signaling lasts unless «Reset call» button is pressed

2.2.5 Power supply units

PSUs PS-103, PS-103-20 types are manufactured in painted metal casings, wall mounted. PSUs supply unregulated voltage 24 V DC to telephones and commutator telephones.

PSUs may connect max. three (for PS-103) and four loads (for PS-103-20). Electrical diagram of PSU includes a switcher, stepdown transformer, rectifier with filter, current overload protection device (fuse – for PS-103 and automatic circuit breaker –

for PS-103-20), and automatic load commutator telephone (to standby power). Power LED is located on the casing side.

2.2.6 External communication devices

2.2.6.1 Headsets

Headset is an external communication device designed for two-way communication together with telephones and commutator telephones.

Headsets HS-3, HS-3P types consist of microphone (middle noise immunity), and two telephones fixed on the metal headband.

Headsets HS-5, HS-5C and HS-5AC types consist of microphone (low noise immunity), and one telephone fixed on the soft (woven) headband.

The System headsets are equipped with manual PTT switch and 3 m cord.

Headsets HS-3P, HS-5C, HS-5AC types have a cord with a waterproof connector (plug or angle plug); HS-3, HS-5 – bare crimped crimped ends.

PTT switch is equipped with three-position toggle switch. In neutral position it disconnects communication circuits of communication device and telephone (commutator telephone); in two other positions – closes the circuits; at the same time, in one extreme position - toggle switch may be fixed, and in another – is shall be held during communication; once it is released – it returns to neutral position.

Headsets HS-5, HS-5C and HS-5AC types operate under max. noise 80 dB, HS-3, HS-3P type – max. 115 dB.

2.2.6.2 Intercom helmets

Intercom helmet is an external communication device, head wear with an integrated headset.

The System includes microtelephone intercom helmets TH-4M type and throat microphone helmets TH-4L type.

Intercom helmets consist of headset fixed on the helmet, PTT switch, microphone or throat microphone, and a cord with waterproof plug that connects helmet to telephones, commutator telephones or socket PB-HS.

All helmets are equipped with a PTT switch with three-position toggle switch. It functions in the same way as the headset switch.

Intercom helmets have summer and winter types.

Special shock absorbers protect user's head against impacts; the back of the helmet has opening flip to protect against atmospheric precipitation.

Intercom helmets are produced in three sizes. For the helmet sizes, see Table 6. Measure head size by perimeter of circle, in centimeters, back point - the most exceeding point of the head back, front point - above the brows. Use centimeter line to measure the size.

Table 6 – Conditional size of intercom helmet

Conditional size of intercom helmet	Head size, cm
I	Max. 56 inclusive
II	57, 58, 59
III	60, 61

Before operation, put on a helmet and adjust its size using adjustments belts at the top and under the chin; regulate the convenient length.

Fix throat microphone on the neck using neck belt; adjust its length.

Intercom helmets operation does not require any special settings.

Intercom helmets TH-4M and TH-4L ensure talk-back communication under max. noise 115 dB and 130 dB, respectively.

2.2.7 Metal cabinet BLTS-BO

The System includes metal cabinets BLTS-BO, hinged type, waterproof, designed for installation on open deck.

It is a metal cabinet with a door made of painted steel. The door is equipped with a lock, opened / closed outside by double bitted key. Lower part has cable glands for external connections.

The cabinet may house any telephone or commutator telephone with any communication device.

3 INTENDED USE

3.1 Operational limitations

All SC shall be connected according to connection diagram and table of connections issued for this order.

All SC shall be grounded.

3.2 Usage preparations

3.2.1 Safety features

Before using the System, provide the following steps:

- train the staff to operate the System, test and control the equipment, and familiarize with occupational safety required for the operation;
- familiarize the staff with all grounding points; check grounding;
- use only standard fuses (PSU);
- de-energize all devices before disconnecting cables, replacing fuses, units and modules;
- the installer shall follow «The technical rules for operation of electric installation» and «Safety rules for operation of electric installation» while testing electrical circuits and insulation resistance.

3.2.2 Visual check procedure

Before switching the SC on, the installer shall:

- observe visually the cable integrity and initial position of the controls on the SC front panels (for commutator telephones – all toggle switches shall be put in down position);
- clean the SC from dust and dirt by clean soft cloth, if necessary;
- check fail-safe cable connections to the SC and their proper grounding.

3.2.3 Instructions on SC switching on

Provide these steps, only if the System has a connection to external power supply.

Power supply to the SC:

- a) switch on power of all PSUs;
- b) check «Power» LED operation on all telephones and commutator telephones;
Note – According to the project, only part of telephones and commutator telephones (not all) may be connected; other users will have no LED light indication.
- c) adjust backlight of controls on all telephones and commutator telephones (if necessary) using dimming button.

If external power network is unavailable, do not provide any of abovementioned steps. The System is ready for operation immediately.

3.3 Use of the System

Before using the System, make sure that you observed 3.2.2 and 3.2.3.

3.3.1 To select a user (connection of call)

Select a System user from any commutator telephone. Telephones have fixed wired connection only to one user (telephone or commutator telephone).

To select a user, group or all users on a commutator telephone, transfer «User» toggle switch to top position. If power is available, LED of the selected user line will start glowing; and if power is not available – the LED will glow only during a call, i.e. while rotating handle of EG.

3.3.2 To initiate a call. All users call

Initiate a call of BTC network user from any System telephone or commutator telephone.

Pick up a receiver or put on external communication device, initiate a call, and wait for the answer (see 3.3.4). On the commutator telephones - prior to that, set up a connection with called user – switch on a toggle switch (see 3.3.1).

To initiate a call, press and hold Call button, if power is available; if power is not available – rotate a cycle of inductor. In both cases, Call LED will start glowing and emit low intermittent sound signal; in the second case – LIO will glow additionally.

Initiate a call to group of users or all users from commutator telephone in the same way; but prior to that switch on corresponding toggles.

Called telephone actuates incoming call signaling; answer the call and establish communication session (see 3.3.4).

To finish the call, release Call button or stop rotating the inductor.

3.3.3 To accept a call

During incoming call, telephone or commutator telephone actuates integrated light and sound signaling, as well as external signaling (if power supply is available and any units connected). Commutator telephones additionally actuate light indication of user line number.

Note – Operation mode of incoming call signaling depends on provided settings of relay unit (see 2.2.4.2).

To reset call signaling, press receiver (communication device) PTT button, or «Reset call» button on telephone or relay unit RBWSB type (if any); or transmit a voice communication to the calling user (ready to communication), so that calling user stops calling (see 3.4.4.).

3.3.4 Communication and answering the call

Prior to communication, set a connection with the required user (see 3.3.1.), initiate a call (see 3.3.2.) or accept a call (see 3.3.3.).

To transmit and listen to voice communication, pick up a receiver, press and hold PPT switch on the receiver.

If you use a headset or intercom helmet with manual switch, use the switch as described below:

- «UP» position – transfer a toggle up; it is fixed (connection to telephone communication circuits);
- «Down» position – transfer a toggle down and hold it (connection to telephone communication circuits);
- «Middle» (neutral) position – toggle is switched off.

To finish a call, release PTT switch on the receiver and put the receiver down to holder.

If you use a headset, switch it off.

3.3.5 Conference call

Conference call is carried out only from commutator telephone; select all users or necessary group of users (see 3.3.1); conference participants may communicate with each other in talk-back mode at the same time.

Apply general list (all) call in conference call mode according to 3.3.2.

3.3.6 Backlight dimming

Telephones and commutator telephones provide for controls backlight (powered from the power mains). Adjust brightness by pressing a brightness button. It is changed cyclically: from highest level to the lowest one (eight levels).

Controls backlight as well as backlight dimming function are powered only from power mains.

Telephones (commutator telephones) will initially set brightness to the middle level (fourth level) every time after power restore.

4 TECHNICAL SERVICE OF THE SYSTEM

4.1 General description

Only qualified staff familiarized with the System composition, structure and operation features shall perform the TS.

In order to provide safe and reliable operation of the System, the staff shall maintain all types of TS:

- TS-0 – daily TS;
- TS № 1 (TS-1) – semi-annual TS;
- TS № 2 (TS-2) – annual TS.

TS-0 is performed on equipment in operation.

TS №1 is performed by the staff on equipment in operation. The TS № 1 results are registered in log of operation (duty log).

TS №2 is performed by the staff on equipment in operation. TS №2 results are registered to the System certificate.

4.2 Safety features

While performing TS, follow the instructions in 3.2.1.

4.3 Maintenance routine

The list of works for all types of TS is given in Table 7.

Maintenance routine procedure is given in checklists (hereinafter – CL), represented in Tables 8-11.

Table 7 – List of works by TS types

CL №	Work	Type of TS		
		TS-0	TS-1	TS-2
1	Visual check of the SC	+	+	+
2	Operational test of the SC	+	+	+
3	Testing public address modes	–	–	+
4	Checking the scope of delivery, SPTA kit condition and operation documentation	–	–	+

Note:
«+» – work is obligatory.
«–» – work is not obligatory.

Table 8 – Checklist № 1. Visual check of the SC

To be done	Routine	Man-hours per 1 SC
Visually examine the SC	1) check appearance of the SC; mechanical damage, paint defects must be absent; marking plates shall be present; legends are to be read easily; 2) clean up the SC surfaces with clean cloth; 3) remove severe contamination, parts of corrosion, oil spots: – from front surfaces – using soap foam preventing it against penetration inside the SC, then all surfaces clean dry by clean cloth and dry up; – from other surfaces – using alcohol soaked cloth; 4) if varnish paint coating is damaged, polish it with sand paper, then clean with alcohol-soaked cloth, cover with varnish AK-113 and dry up	1 person 5 mins
Check reliability of cable and bus connection to the SC	1) check that connectors and attaching screws are fastened tight; provide further fastening if needed; 2) check the cable integrity (mechanical damage shall be absent)	1 person 5 mins

Table 9 – CL № 2. SC operability check

Fault	To do	Man-hours per 1 SC
Check operation of telephones and commutator telephones	1) check operation of Power LED and controls backlight (if checked telephone (commutator telephone) is connected to power supply); adjust backlight if necessary; 2) check inductor operation – rotate it and make sure that LED «Inductor on» is glowing	1 person 5 minutes per 1 SC

Table 10 – CL № 3. LS and BTC modes check

To do	Works	Man-hours per 1 SC
Check SC operation and communication	1) perform test calls from each telephone and commutator telephone according to the list of users: a) once a connection is set, check operation of selected user line LED (only commutator telephones); b) initiate a call, check actuation of outgoing call signaling (intermittent sound signal and «Call» LED); c) initiate a call using inductor, check operation of LIO; d) initiate a call, check actuation of incoming call signaling on the called telephone (commutator telephone) – local (call sound signal and Call LED) and external (external signaling units)	2 persons 1 hour

	2) perform a control communication session (using telephone receiver and external communication device), test connection of communication lines, transmission of voice communication and quality (speech legibility); during communication make sure that PTT switches of communication devices operate correctly (no malfunctions or noise)	2 persons 1 hour
	3) for portable telephone PH2-5C-PO, additionally control condition of connector and matching sockets; test every socket, connect it and set a communication with users; test a connector for headset	2 persons 1 hour

Table 11 – Checklist №4. Check of scope of delivery, SPTA kit condition and operation documentation

To be done	Routine	Man-hours per 1 SC
Check of scope of delivery, SPTA kit condition and operation documentation	1) compare SPTA kit items to operational documentation represented in section 4 «The scope of delivery» of the System Certificate; 2) check the quality of every SPTA kit item, storage time; SPTA kit shall be fully recompleted in case of its use (according to 4.4); 3) recomplete SPTA kit	1 person 1 hour

4.4 Instructions on SPTA kit

SPTA kit is delivered together with the System and used to support operating condition of the System by replacing faulty SC.

Portable SPTA kit shall contain items listed in SPTA kit list.

4.5 Preservation

The System, SPTA kit and set of operational documents are stored in preserved condition in Manufacturer’s packaging boxes. Time of second preservation – 2 years from the date of System handling over on the Manufacturer’s plant.

The preservation is done in full terms, for 2 years, applying protection and packaging.

Represervation may be carried by the Buyer or ship crew if necessary.

The second preservation (represervation) is done in heated rooms in the same order as the preservation.

The represerved System, SPTA kit and set of operational documents are placed in package. The package is sealed.

The storage time for the represerved System – 2 years.

5 CURRENT REPAIR

5.1 General description

Within time of warranty the System is opened with witness of the Manufacturer representative drawing up an Act of opening.

If the System is used outside its regular place of use, and SC failed, replacement of fuses and LEDs, etc. from portable SPTA kit is allowed without presence of the Manufacturer representative. Appropriate record is made in the System Certificate.

Once the System is returned back to the regular place of use, a representative of the Manufacturer should be called in to draw up a damage claim.

Complete portable SPTA kit at regular place of use from basic SPTA kit.

5.2 Safety features

Any repair works must be provided by qualified personnel.

All SC shall be grounded.

Use rubber rug in front of power supply units and amplifiers.

Replacement of fuse links or defective parts, boards and modules when power is ON is **STRICTLY PROHIBITED**.

It is **PROHIBITED** to put a poster «DO NOT switch on! Under Operation!», when power supply switch is in OFF position.

Installation and repair works are **PROHIBITED** in the room, where less than 2 people are present.

6 CURRENT REPAIR OF SC

6.1 Commutator telephones and telephones

The list of possible malfunctions and troubleshooting is represented in Table 12.

The staff shall eliminate malfunctions of commutator telephones and telephones using SPTA kit portable.

Table 12 – The list of possible malfunctions and troubleshooting

Malfunction	Possible reasons	Instructions
1 No operation (glowing) of «Power» LED	PSU failure (power is not supplied)	Replace the fuse (de-energize the SC) using SPTA kit
		Supply power to PSU
		See below section <i>Power supply units</i>
2 «Call» button does not initiate a call	Fuse malfunction on telephone (commutator telephone) on power circuit	Replace the fuse
		No actions required
3 No buttons backlight (dimming button does not work)	Electric generator malfunction, or inductor circuit contact malfunction	Replace the telephone (commutator telephone)
	Contact malfunction (connection) in user line or connector	Check communication line and connection reliability, switching on connectors and terminals contacts
While rotating handle of electric generator, «Inductor on» LED is not glowing	Contact malfunction in switch circuit (toggle) of user select (only for commutator telephones)	1) Check the toggle circuit, restore contact 2) Replace a telephone
	Contact malfunction (connection) in user line or connector	Check communication line and connection, switch on connectors and terminals contacts
While rotating handle of electric generator, call is not performed (but LEDs «Inductor on» and «Call» are glowing)	No power mains	Supply power to signaling units (switch on power mains)
	Fuse malfunction on signaling unit control circuit	Replace the fuse
	Contact malfunction (connection) in signaling unit connection circuit	1) Check the connection circuit, restore contact 2) Replace the unit
	Signaling unit malfunction	Replace the unit; replace a bulb in flashing lamp
No local (and external) signaling of incoming call (No operation (glowing) of «Call» LED; no sound signal)		
External signaling units do not operate during incoming call (see also section of <i>relay unit RBWSB</i>)		

Malfunction	Possible reasons	Instructions
No connection with calling user, incoming call is set (only for commutator telephones)	Contact malfunction in switch circuit (toggle) of user select	1 Check the toggle circuit, restore contact 2 Replace the commutator telephone
No transmission of voice communication between users (including commutator telephones in case of correct signaling for user connection)	Not enough power for telephones operation (commutator telephones)	Rotate the handle of inductor
	No contact in receiver connection circuit	Check and restore contact in the receiver connection circuit
	No contact in external communication device connection circuit	Check and restore contact in the external communication device connection circuit (communication lines, connectors, socket, manual headset switch, intercom helmet)
	Telephone receiver malfunction (microphone module or speaker)	Replace the telephone receiver
	Headset (helmet) malfunction	Replace the headset (helmet)

6.2 Power supply units

Control PSU operation by Power switch LED (available power supply mains); check constant voltage 24 V (23...28 V – depending on the load) on the output terminals of PSU.

The list of possible malfunctions and troubleshooting of PSU is represented in Table 13.

Troubleshooting of PSU malfunctions is carried out using SPTA kit portable.

Table 13 – The list of possible malfunctions and troubleshooting of PSU

Malfunction	Possible reasons	Instructions
Power button is switched on, but power indicator is not glowing	No power mains	Provide external power
Power indicator is on, but there is no output voltage	Fuse malfunction	Replace the fuse
	Transformer malfunction	Replace the transformer
	Board malfunction	Replace the board
No output voltage in case of main power failure (no switch-over to standby power supply)	No power of standby network	Supply power from standby network
	Switching circuit on board is faulty	Replace the board
	Standby connection is not included in project	No actions required

6.3 Relay unit

Table 14 – The list of possible malfunctions and troubleshooting of relay unit

Malfunction	Possible reasons	Instructions
External signaling units do not operate at incoming call (see similar problem in <i>Telephones and commutator telephones</i>)	Fuse malfunction in signaling unit output circuit	Replace the fuse
	No power mains	Supply power
	Communication line failure of telephone or commutator telephone	Check the line and repair communication line
	Malfunction of input or output circuit, or board switching circuit malfunction	Replace the board

7 TRANSPORTATION AND STORAGE

The System must be stored in packaging inside areas complying with the required storage conditions (plus 5 °C...plus 40 °C) without exceeding the concentration of dust, oil, moisture and aggressive impurities in the air for the working areas of production facilities.

The System must be transported in the Manufacturer's transportation package in enclosed means of transport.

Types of shipment:

- motor vehicle and railroad transportation in closed means of transport (covered cars, multipurpose containers);
- air transportation (in sealed and heated compartments);
- sea transportation (in dry working areas).

The System must be transported in compliance with transportation rules applicable for each means of transport.

During loading / unloading operations and transportation, the requirements indicated on warning labels on the boxes/packaging must be observed, and no impacts are permitted since they can affect the safety and performance of the System.

Inside the means of transport, the packed device must be firmly secured / fastened.

After storage or transportation of the SC below plus 10 °C, it must be unpacked only in heated premises and left in normal climate conditions for 12 hours beforehand.

8 DISPOSAL

New equipment, the parts of the System damaged during operation, and any used up equipment must not be disposed as standard household wastes, since they contain the materials suitable for re-use.

Decommissioned and non-used components of the System must be delivered to a special waste disposal center licensed by local authorities. You can also send used up equipment / unit to the manufacturer for its further disposal.

Proper disposal of the System components allows avoiding possible negative environmental and health impacts, and it also allows for proper restoration of components with substantial energy and resources saving.

During operation and upon completion of its service life, the equipment is not hazardous for health and environment.

This unit must be disposed according to the rules applied to electronic devices.



Any products marked with a crossed trash bin must be disposed separately from standard household wastes.

APPENDIX A SPTA KIT LIST

Table A.1 – SPTA kit

Name	Quantity
Fuse 5A (5x20 mm)	1
Fuse 2A (5x20 mm)	1
Fuse 10A (5x20 mm)	1
Bootlace terminal, wire 2.5 mm ²	100
Bootlace terminal crimper 0.4...4.0 mm ²	1
Cross screwdriver, PH1	1
Straight-blade screwdriver, blade width 3.5 mm, thickness 0.6 mm	1
System units (select from 1.3.2)	0 or more*
* Delivered on request, specify name and quantity at order.	

APPENDIX B DESCRIPTION OF THE SC

B.1 Telephones and commutator telephones

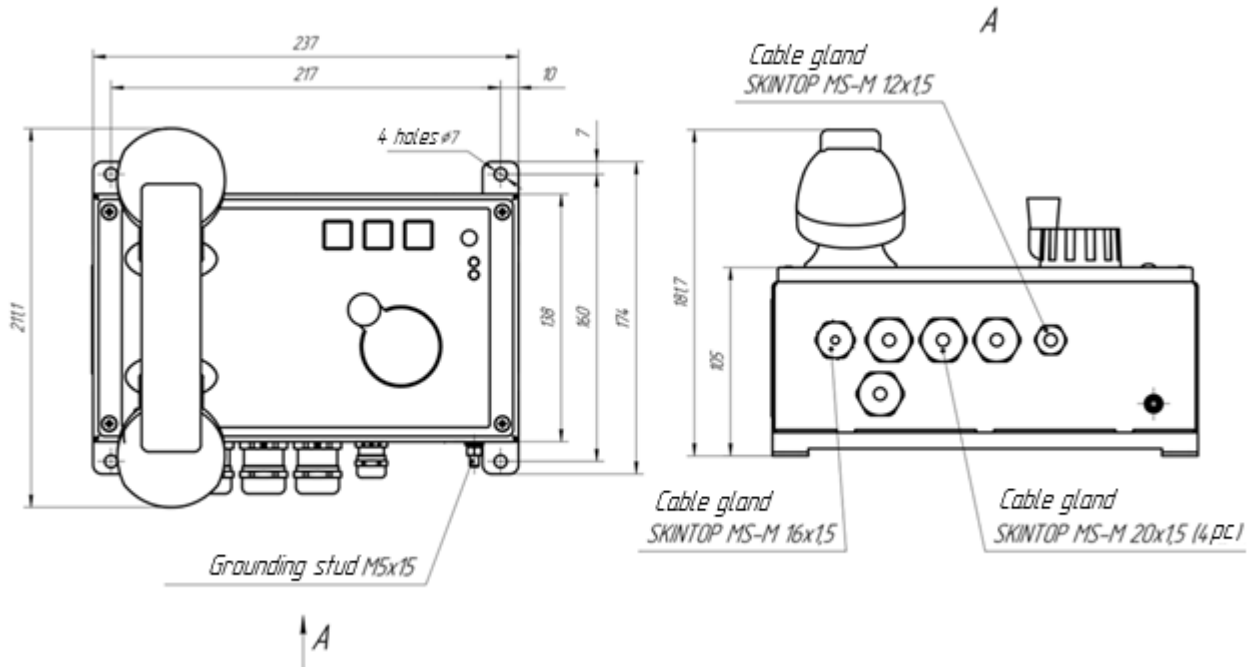

Telephone PH-1-W

Description: single-channel telephone for application in battery less communication systems.

Features:

- operation in BTC and public address modes;
- controls backlight;
- incoming call LEDs, Inductor on LED, external power LED;
- external signaling units may be connected;
- headset or intercom helmet may be connected.

Technical specifications:

- power consumption:
 - wait mode 3 W;
 - talk mode 15 W;
- number of lines: one;
- IP rating: IP56;
- operating temperature: -40 °C...+55 °C;
- weight: 3.6 kg.

Mounting type: wall.

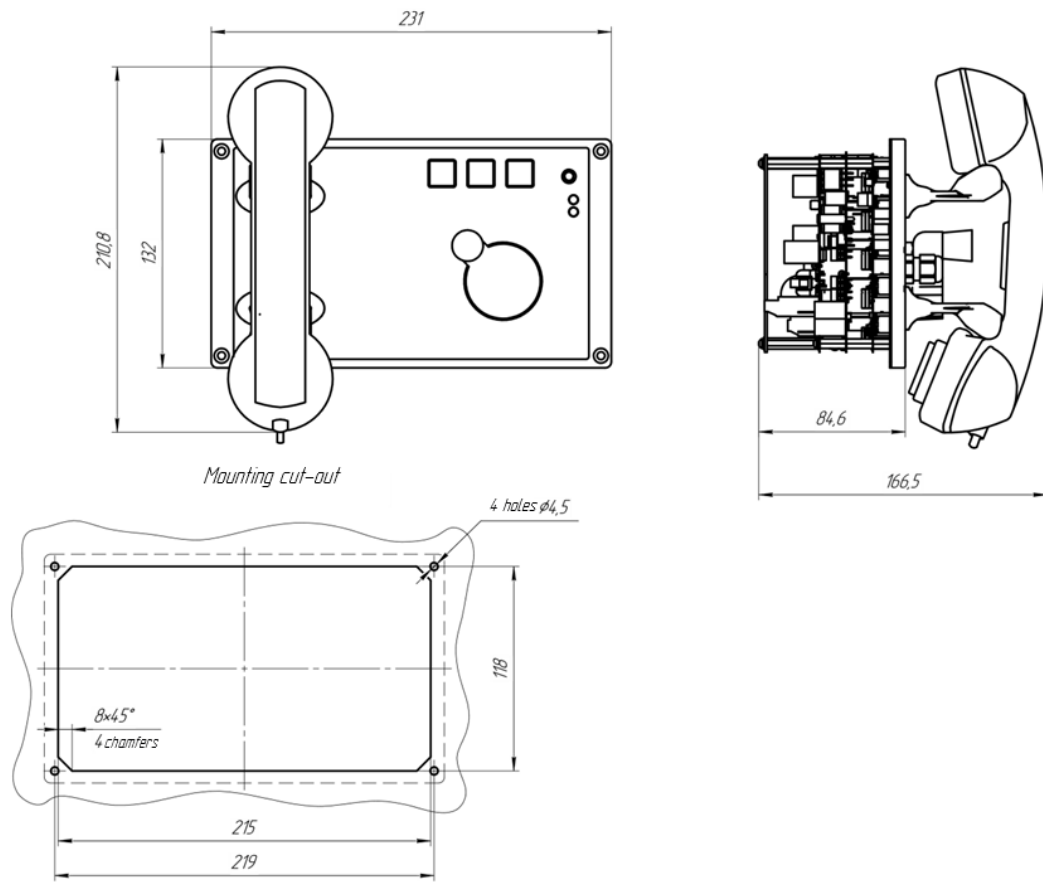

Telephone PH-1L

Description: single-channel telephone for application in battery less communication systems.

Features:

- operation in BTC and public address modes;
- controls backlight;
- incoming call LEDs, Inductor on LED, external power LED;
- external signaling units may be connected;
- headset or intercom helmet may be connected.

Technical specifications:

- power consumption:
 - wait mode 3 W;
 - talk mode 15 W;
- number of lines: one;
- IP rating:
 - rear side IP22;
 - front side IP56.
- operating temperature: $-40\text{ }^{\circ}\text{C} \dots +55\text{ }^{\circ}\text{C}$;
- weight: 2.5 kg.

Mounting type: panel.

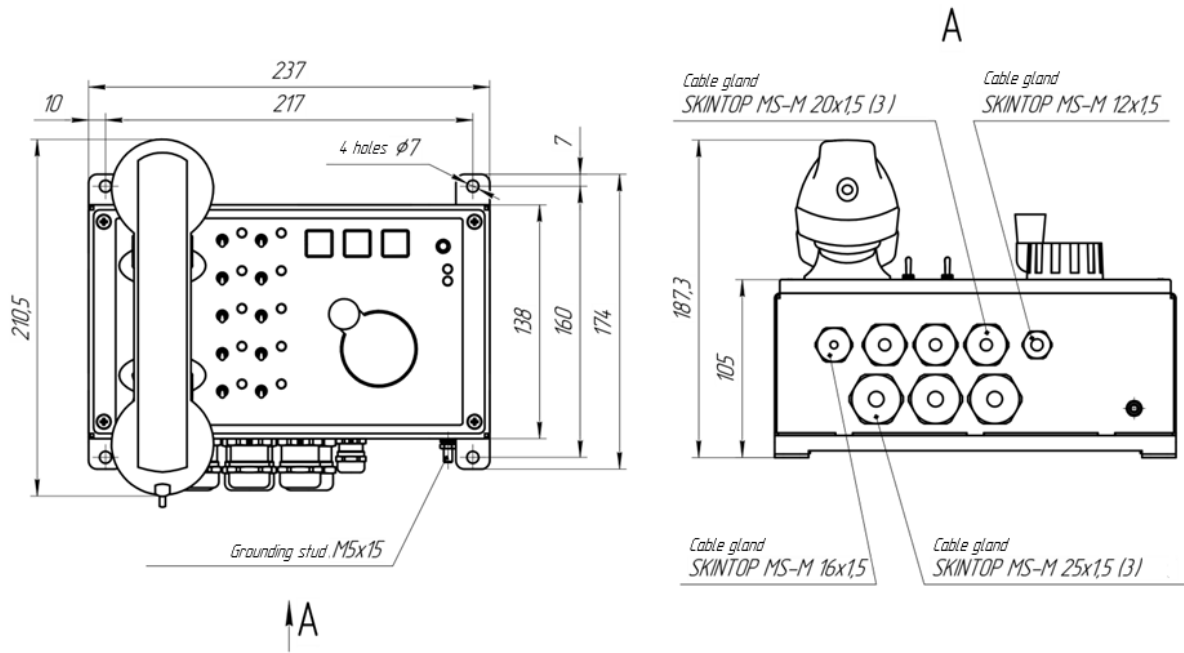

Commutator telephones PH2-5C-W, PH2-10C-W

Description: commutator telephones for 5 or 10 lines for application in battery less communication systems.

Features:

- operation in BTC and public address modes;
- controls backlight;
- incoming call LEDs, Inductor on LED, external power LED;
- external signaling units may be connected;
- headset and intercom helmet may be connected.

Technical specifications:

- power consumption:
 - wait mode 3 W;
 - talk mode 15 W;
- number of lines: 5, 10;
- IP rating: IP56;
- operating temperature: -40 °C...+55 °C;
- weight: 3.6 kg.

Mounting type: wall.

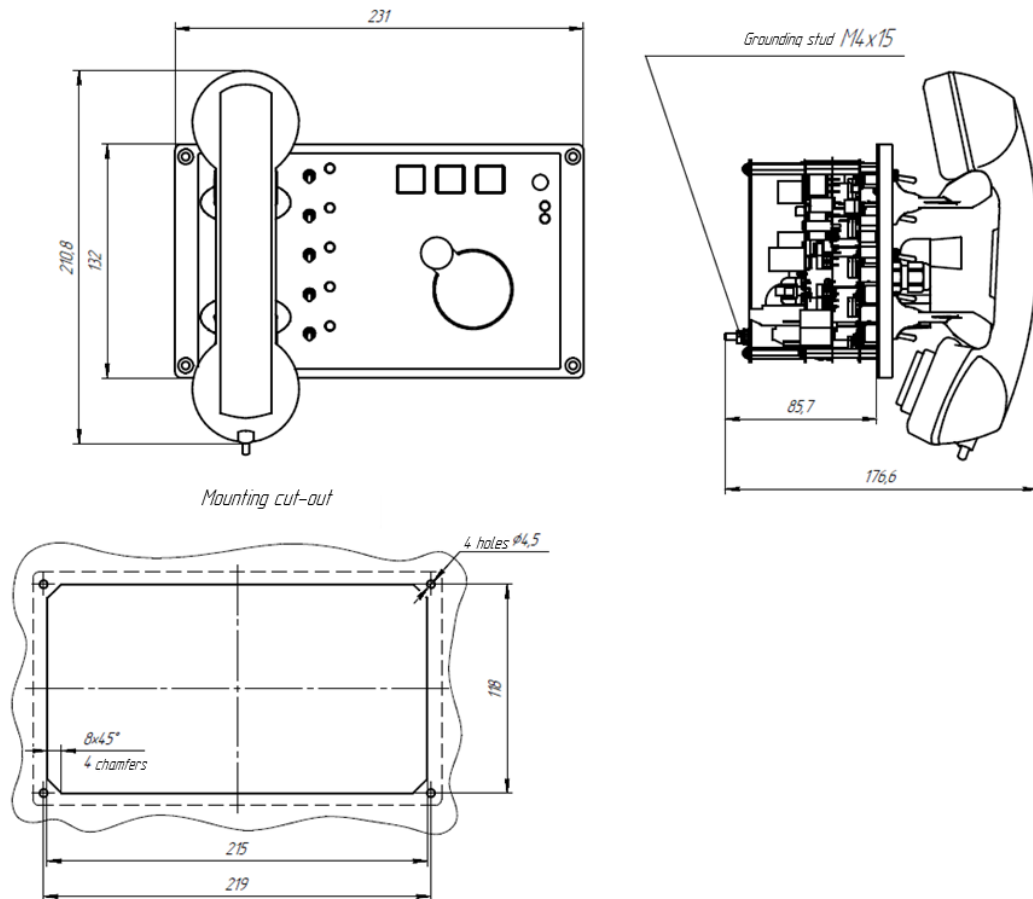

Commutator telephones PH2-5C-P, PH2-10C-P

Description: commutator telephones for 5 or 10 lines for application in battery less communication systems.

Features:

- operation in BTC and public address modes;
- controls backlight;
- incoming call LEDs, Indicator on LED, external power LED;
- external signaling units may be connected;
- headset or intercom helmet may be connected.

Technical specifications:

- power consumption:
 - wait mode 3 W;
 - talk mode 15 W;
- number of lines: 5, 10;
- IP rating:
 - IP22 – rear side;
 - IP56 – front side.
- operating temperature: $-40\text{ }^{\circ}\text{C} \dots +55\text{ }^{\circ}\text{C}$;
- weight: 2.1 kg.

Mounting type: panel.

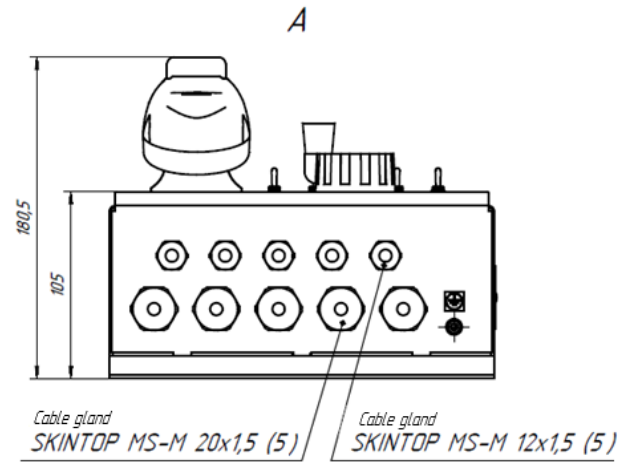
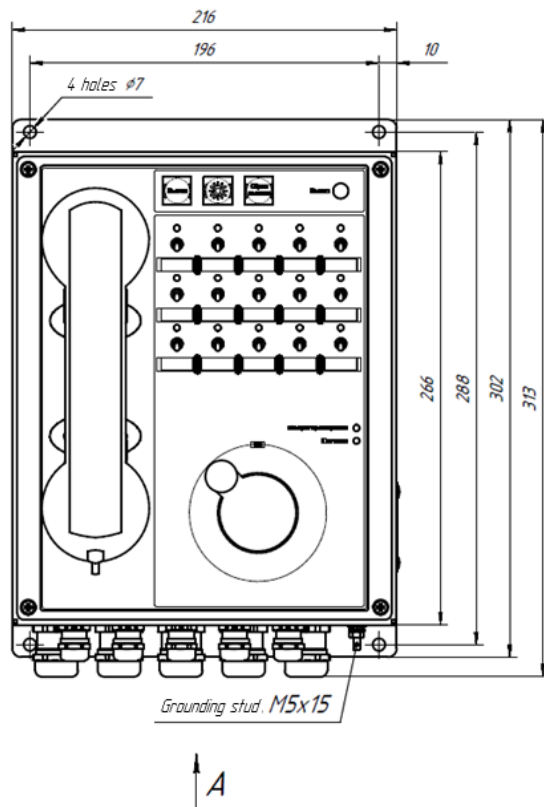

Commutator telephones PH2-15C-W, PH2-20C-W, PH2-25C-W

Description: commutator telephones for 15, 20 or 25 lines for application in battery less communication systems.

Features:

- operation in BTC and public address modes;
- controls backlight;
- incoming call LEDs, Inductor on LED, external power LED;
- external signaling units may be connected;
- headset or intercom helmet may be connected.

Technical specifications:

- power consumption:
 - wait mode 3 W;
 - talk mode 15 W;
- number of lines: 15, 20, 25;
- IP rating: IP56;
- operating temperature: -40 °C...+55 °C;
- weight:
 - PH2-15C-W – 4.6 kg;
 - PH2-20C-W – 4.7 kg;
 - PH2-25C-W – 4.6 kg.

Mounting type: wall.

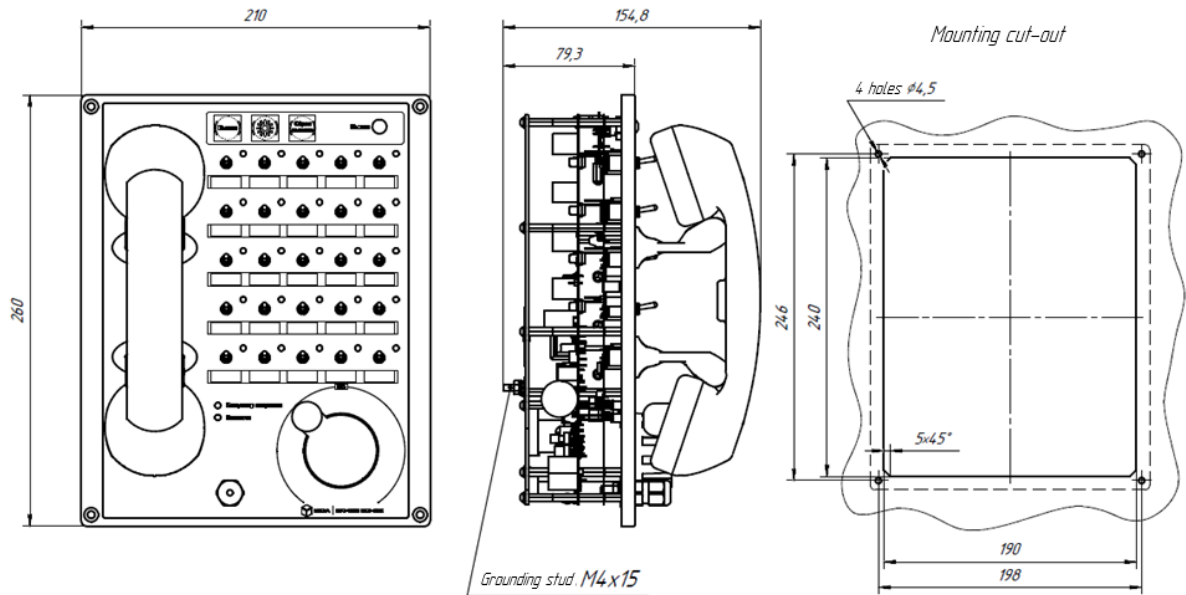

Commutator telephones PH2-15C-P, PH2-20C-P, PH2-25C-P

Description: commutator telephones for 15, 20 or 25 lines for application in battery less communication systems.

Features:

- operation in BTC and public address modes;
- controls backlight;
- incoming call LEDs, Indicator on LED, external power LED;
- external signaling units may be connected;
- headset or intercom helmet may be connected.

Technical specifications:

- power consumption:
 - wait mode 3 W;
 - talk mode – 15 W;
- number of users: 15, 20, 25;
- IP rating:
 - IP22 – rear side;
 - IP56 – front side.
- operating temperature: $-40...+55\text{ }^{\circ}\text{C}$;
- weight: 3.0 kg.

Mounting type: panel.

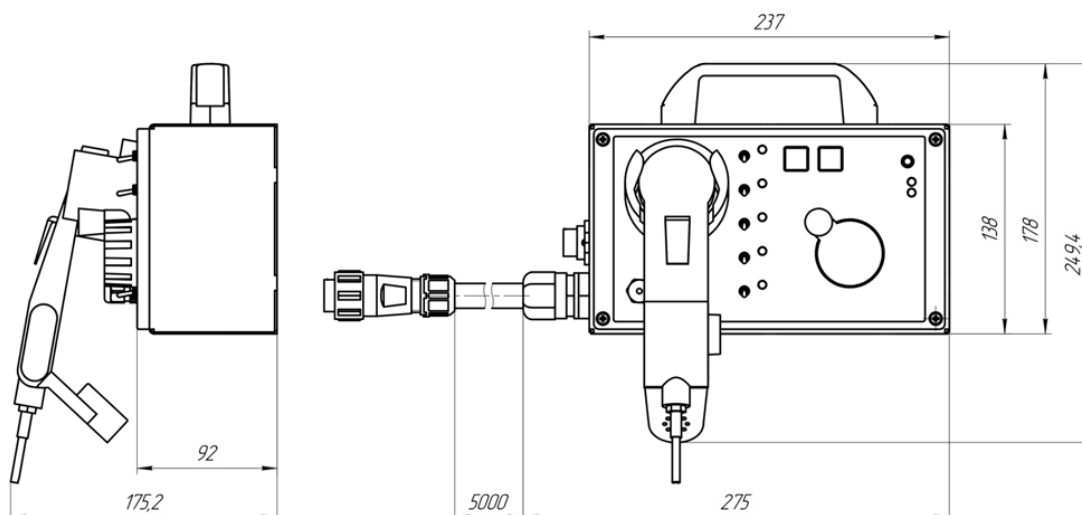

Portable telephone PH2-5C-PO

Description: Telephone for 5 lines for application in battery less communication system, portable.

Features:

- operation in BTC and public address modes;
- controls backlight;
- incoming call LEDs, Indicator on LED, external power LED;
- external signaling units may be connected;
- headset or intercom helmet may be connected.

Technical specifications:

- power consumption:
 - wait mode 3 W;
 - talk mode – 15 W;
- number of users: 5;
- IP rating: IP56;
- operating temperature: -40 °C...+55 °C;
- weight: 2.5 kg.

Mounting type: wall.

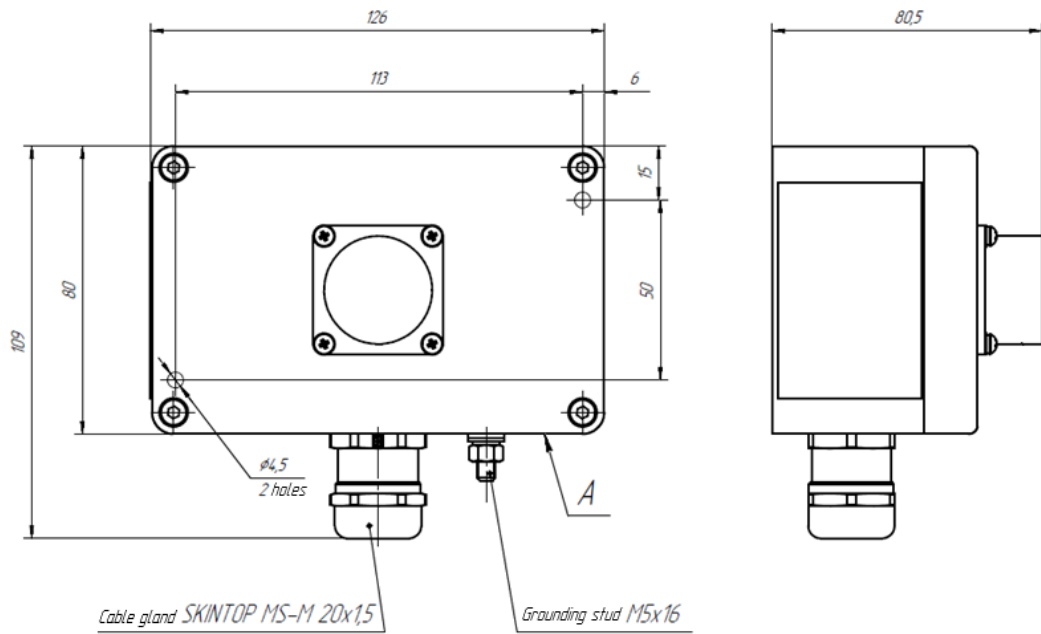

Socket S-BLT

Description: socket S-BLT is designed to connect portable telephone PH2-5C-PO.

Technical specifications:

- operating temperature: $-40\text{ °C} \dots +55\text{ °C}$;
- IP rating: IP56;
- weight: 0.8 kg.

Mounting: wall.

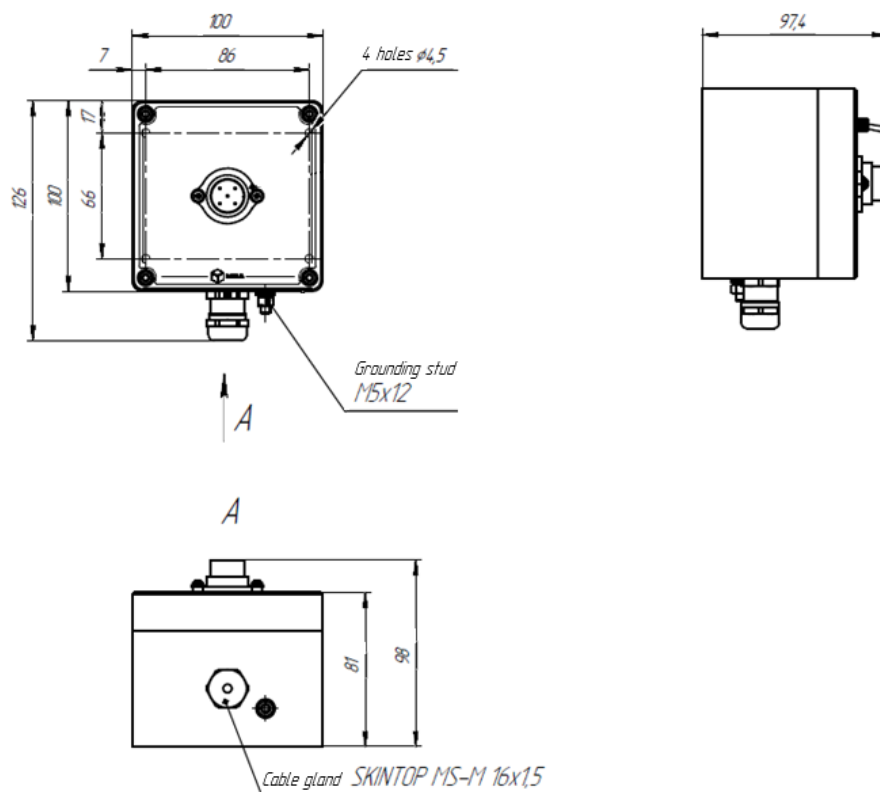

Socket PB-HS

Description: remote connection point for headset to telephone.

Features:

- waterproof type;
- equipped with waterproof connector with protective cover.

Technical specifications:

- material: aluminum;
- IP rating: IP56;
- operating temperature: $-40\text{ }^{\circ}\text{C} \dots +55\text{ }^{\circ}\text{C}$;
- weight: 0.8 kg.

Mounting: wall.

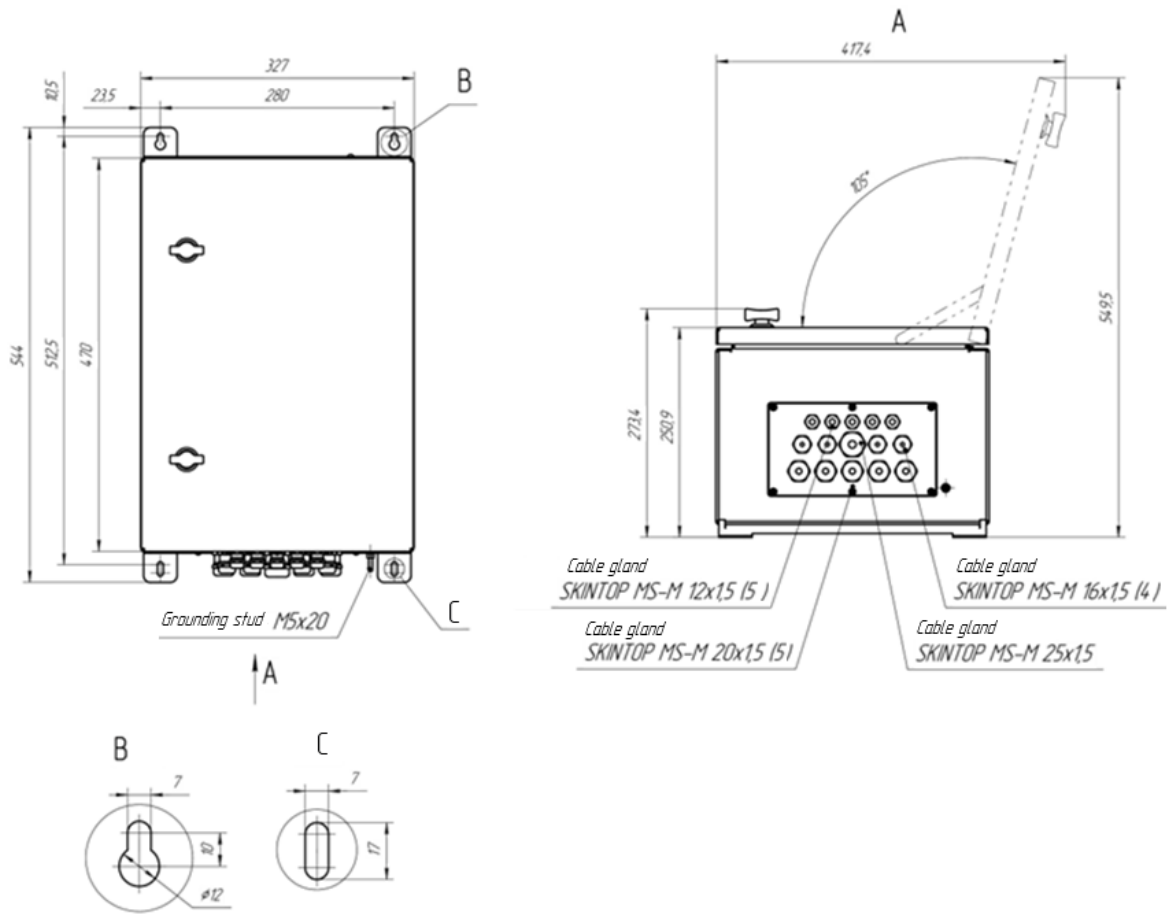

Metal waterproof cabinet BLTS-BO

Description: Metal waterproof cabinet designed to house SC on open deck and protect them against moisture ingress.

Features:

- equipped with a door to access to integrated SC and internal mounting panel;
- door is equipped with a lock (unlock) mechanism and door stopper to keep it open;
- recommended for telephones installed on open deck.

Technical specifications:

- operating temperature: $-40\text{ }^{\circ}\text{C} \dots +55\text{ }^{\circ}\text{C}$;
- IP rating: IP56;
- weight: 12.4 kg.

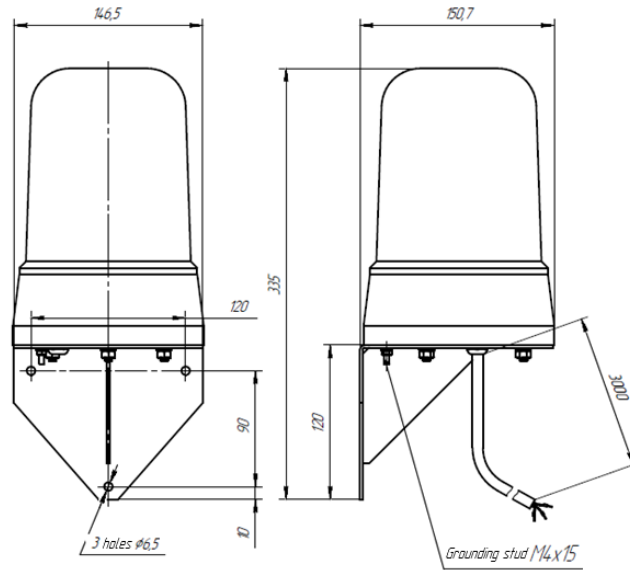

Flashing lamp RL-24, RL-220

Description: flashing lamp (rotating) to ensure light signaling of incoming call in noisy environment.

Features:

- globe colours: red, orange, green, blue;
- lamp connection:
 - RL-24 to relay unit RBWSB-24 and telephones (except portable ones);
 - RL-220 only to relay unit RBWSB-220;
- bracket at option.

Technical specifications:

- power supply voltage:
 - for RL-24 – 24 V DC;
 - for RL-220 – 220 V AC, 50 (60) Hz;
- power:
 - for RL-24 – 65 W;
 - for RL-220 – 45 W;
- light:
 - for RL-24 – halogen bulb (24 V);
 - for RL-220 – incandescent bulb (220 V);
- rotation frequency: 180 rotations per minute;
- operating temperature: –15 °C...+55 °C;
- IP rating: IP56;
- weight:
 - for RL-24 – 0.9 kg;
 - for RL-220 – 1.1 kg.

Mounting type: wall, on a bracket.

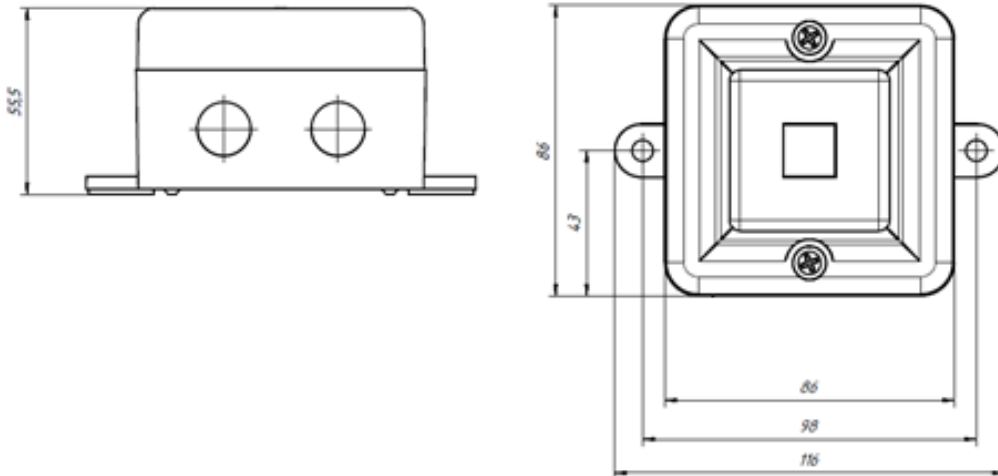

Sound signaling unit A-24, A-220

Description: Sound signaling unit for incoming call in noisy environment.

Features:

- waterproof type;
- 10 signal tones;
- signaling unit connection:
 - A-24 – to relay unit RBWSB-24 and telephones (except portable);
 - A-220 – only to relay unit RBWSB-220;
- casing colours: grey, red;
- delivered with cable glands;
- cable is led using a hole «knock-out» blank plug (performed by stamping).

Technical specifications:

- material – impact-resistant plastic (red or grey);
- power supply voltage:
 - for A-24 – 24 V DC;
 - for A-220 – 220 V AC, 50 (60) Hz;
- power:
 - for A-24 – 0.6 W;
 - for A-220 – 3.0 W;
- frequency of signal:
 - for A-24 – 420...1200 Hz;
 - for A-220, depending on settings – 420...2900 Hz;
- max. sound pressure: 100 dB (adjustment within 30...100 dB)
- IP rating: IP56;
- operating temperature: –40 °C...+55 °C;
- weight: 0.3 kg.

Mounting type: wall.

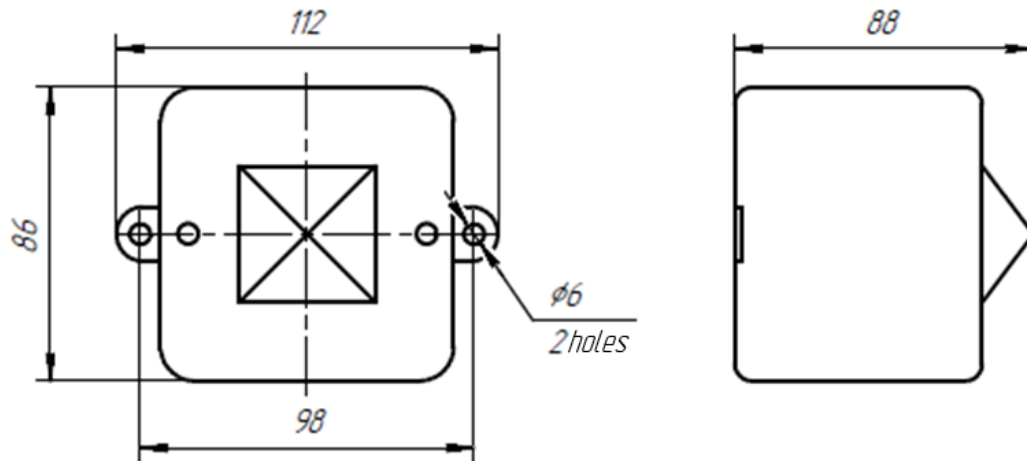

Light signaling unit L-24, L-220

Description: Light signaling unit for incoming call in noisy environment.

Features:

- globe colours: amber, blue, white, green, red, yellow;
- signaling unit connection:
 - L-24 – to relay unit RBWSB-24 and telephones (except potable);
 - L-220 – only to relay unit RBWSB-220;
- cable is led using a hole «knock-out» blank plug (performed by stamping).

Technical specifications:

- material: polycarbonate (impact-proof);
- power supply:
 - for L-24 – 24 V DC (20..28 V);
 - for L-220 – 220 V AC 50 ± 10 % (60 Hz ± 10 %);
- power:
 - for L-24 – 7.5 W;
 - for L-220 – 8.5 W;
- flashes: 60...90 flashes per minute;
- bulb type: xenon;
- light intensity: 250 cd;
- operating temperature: –25 °C...+55 °C;
- IP rating: IP56;
- weight 0.2 kg.

Mounting type: wall.

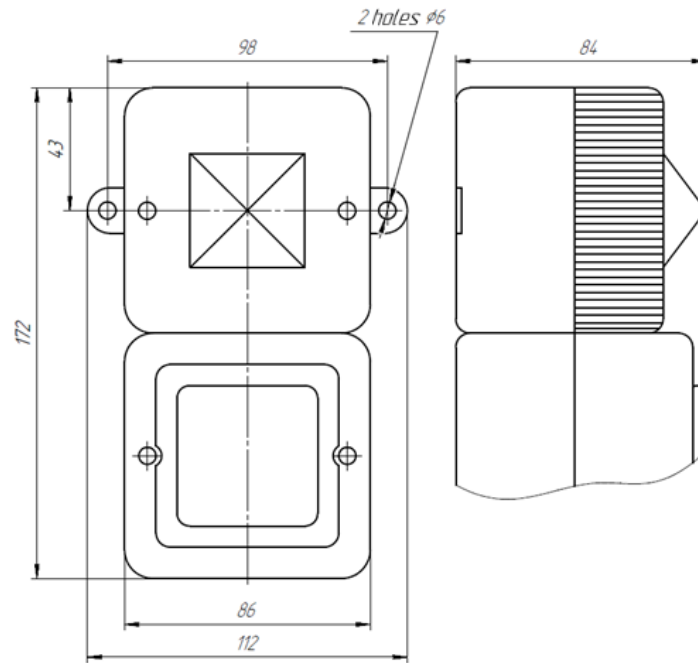

Sound-light signaling unit AL-24, AL-220 type

Description: Sound-light signaling unit for incoming call in noisy environment.

Features:

- waterproof;
- 10 signal tones;
- signaling unit connection:
 - AL-24 to relay unit RBWSB-24 and telephones (except portable);
 - AL-220 only to relay unit RBWSB-220;
- casing colours: grey, red, white;
- globe colours: amber, blue, green, red, yellow.
- equipped with cable glands metal or plastic;
- cable is led using a hole «knock-out» blank plug (performed by stamping).

Technical specifications:

- material: plastic, impact-proof;
- power:
 - for AL-24 – 8 W;
 - for AL-220 – 11 W;
- power supply:
 - for AL-24 – 24 V DC;
 - for AL-220 – 220 V AC 50 (60) Hz;
- signal frequency (depending on settings):
 - for AL-24 – 420...1200 Hz;
 - for AL-220 – 420...2900 Hz;
- flash frequency: 1 Hz;
- flash brightness: 200 cd (xenon);
- max. sound pressure: 105 dB (adjustment within 30...105 dB);
- operating temperature: –15 °C...+55 °C;
- IP rating: IP56;
- weight: 0.5 kg.

Mounting type: wall.

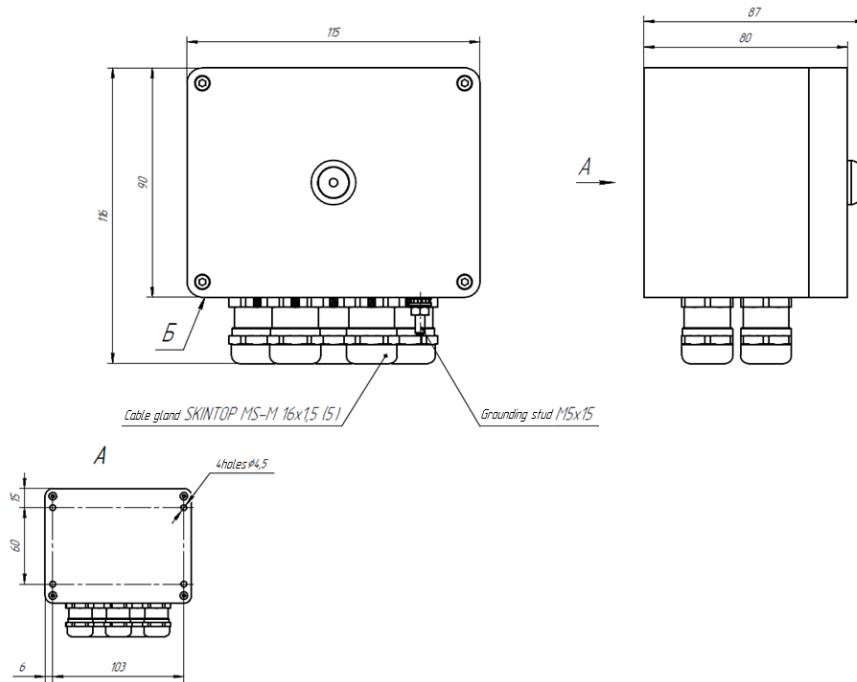

Relay unit RBWSB-24, RBWSB-220

Description: external signaling unit to connect external alarm units; ensures switching of external power to the connected devices.

Features:

- used with all telephones (except portable);
- light and sound signaling units may be connected (power 220 V or 24 V);
- call reset button and incoming call LED;
- supplies call signal to alarm units;
- ensures call signaling (after call is ended by user) in modes: continuous (until reset), with delay 10 sec, immediate call finish.

Technical specifications:

- material: plastic;
- input voltage:
 - for RBWSB-220 – 220 V AC 50 (60) Hz;
 - for RBWSB-24 – 24 V DC;
- max. switching current: 10 A;
- connected loads: 3;
- control signal: dry contact;
- reset button with input port to reset external devices;
- IP rating: IP56;
- operating temperature: -40 °C...+55 °C;
- weight: 1.4 kg.

Mounting type: wall.

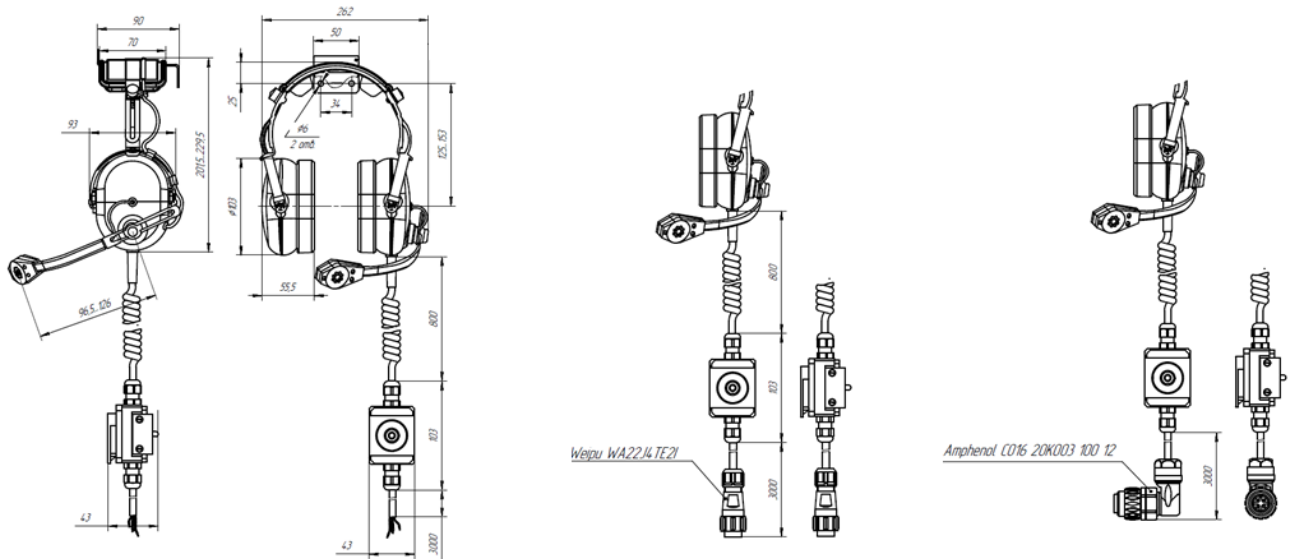

Headset HS-3, HS-3P, HS-3P with angle connector

Description: external communication device for talk-back communication in noisy environment.

Features:

- freedom to move;
- PTT switch;
- may be connected to telephones and commutator telephones;
- delivered with a bracket;
- CE type cord may be used;
- cable length from headset to PTT: 0.8 m;
- cable HS-3 with bare ends;
- cable HS-3P with plug type or angle plug type connector.

Technical specifications:

- headset type: passive, monophonic;
- close-talking response at frequency 300... 3400 Hz (idle run): 16 dB;
- module of microphone impedance at frequency 1000 Hz: 600±120;
- roughness of close-talking response microphone frequency characteristic within 300...3400 Hz: 12 dB;
- microphone axial selectivity to spherical field at frequency 300 Hz: 10 dB;
- output voltage of electroacoustic interaction of headset transmission at noise pressure 104 dB at load 600 Ohm: 1.25...1 mV;
- noise suppression within 100...400 Hz: at least 8 dB;
- operation at noise: max. 115 dB;
- operating temperature: -40 °C...+55 °C;
- IP rating: IP56;
- weight: 0.7 kg.

Mounting type: wall (storage).

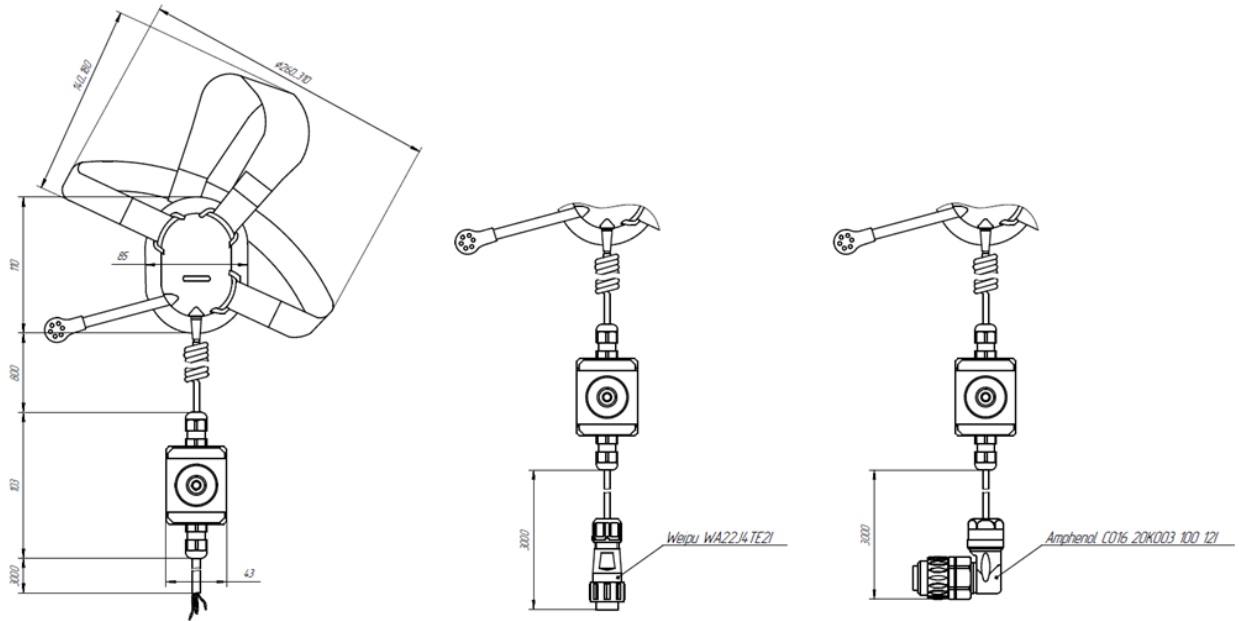

Headset HS-5, HS-5C, HS-5AC

Description: external communication device for talk-back communication in normal noisy environment.

Features:

- one-eared;
- freedom to move;
- PTT switch;
- adjusted headband;
- flexible adjusted microphone and fixed;
- connected to telephones and commutator telephones;
- cord CE type may be used;
- cable HS-3 with bare ends;
- cable HS-3C with plug type connector;
- cable HS-3AC with angle plug type connector.

Technical specifications:

- headset type: passive, monophonic;
- operating frequency range: 150...7000 Hz;
- close-talking response at frequency 1000 Hz (idle run): 0.4...1.1 mV/Pa;
- module of microphone impedance at frequency 1000 Hz: 300 ± 60 ;
- roughness of close-talking response microphone frequency characteristic within 150...7000 Hz: 15 dB;
- microphone axial selectivity to spherical field at frequency 150 Hz: 8 dB;
- output voltage of electroacoustic interaction of headset transmission at noise pressure 1000 Hz at load 3 kOhm: 10 mV;
- operation at noise: max. 120 dB;
- operating temperature: $-40\text{ }^{\circ}\text{C} \dots +55\text{ }^{\circ}\text{C}$;
- IP rating: IP56;
- weight: 6.0 kg.

Mounting type: wall, on a bracket (storage).

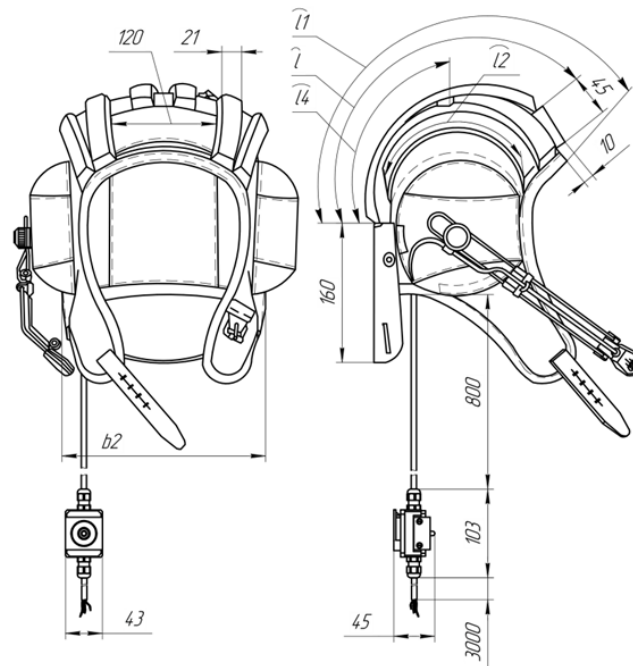

Intercom helmet type		Size measurement, mm										
		<i>l</i>	<i>l</i> ₁	<i>l</i> ₂	<i>l</i> ₃	<i>l</i> ₄	<i>l</i> ₅	<i>b</i>	<i>b</i> ₁	<i>b</i> ₂	<i>s</i>	<i>s</i> ₁
TH-4M-S (I)		310	325	238	120	153	160	21	45	200	10	10
TH-4M-S (II)	TH-4M-W (I)	323	338	242	120	161	160	21	45	205	10	10
TH-4M-S (III)	TH-4M-W (II)	336	351	246	120	169	160	21	45	210	10	10
	TH-4M-W (III)	349	364	250	120	182	165	21	45	215	10	10

Note – I, II or III –intercom helmet size.

Intercom helmet with microphone headset TH-4M-S, TH-4M-W, TH-4M-S-C, TH-4M-W-C, TH-4M-S-AC, TH-4M-W-AC

Description: external communication device.

Features:

- freedom to move;
- PTT switch type;
- may be connected to telephones and commutator tele-phones;
- CE type cord may be used;
- summer and winter types;
- cable TH-4S and TH-4W with bare ends;
- cable TH-4M-S-C and TH-4M-W-C with plug connector;
- cable TH-4M-S-AC, TH-4M-W-AC with angle plug type connector.

Technical specifications:

- operating frequency range: 150...7000 Hz;
- word intelligibility at acoustic noise max. 120 dB: at least 92 %;
- operating temperature: –40 °C...+55 °C;
- IP rating: IP56;
- weight of intercom helmet:
 - summer, max. 0.95 kg;
 - winter, max. 1.05 kg.

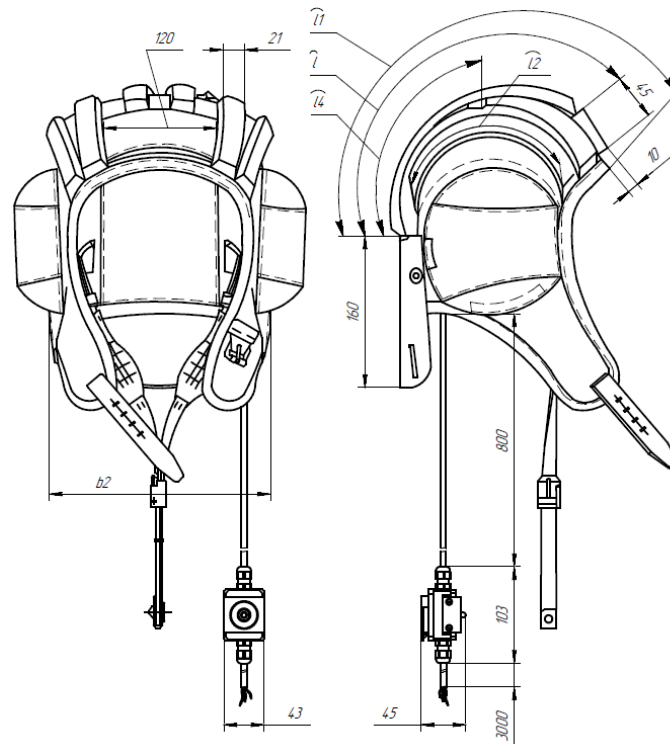

Intercom helmet type		Size measurement, mm										
		<i>l</i>	<i>l</i> ₁	<i>l</i> ₂	<i>l</i> ₃	<i>l</i> ₄	<i>l</i> ₅	<i>b</i>	<i>b</i> ₁	<i>b</i> ₂	<i>s</i>	<i>s</i> ₁
TH-4L-S (I)		310	325	238	120	153	160	21	45	200	10	10
TH-4L-S (II)	TH-4L-W (I)	323	338	242	120	161	160	21	45	205	10	10
TH-4L-S (III)	TH-4L-W (II)	336	351	246	120	169	160	21	45	210	10	10
	TH-4L-W (III)	349	364	250	120	182	165	21	45	215	10	10

Note – I, II or III –intercom helmet size.

Intercom helmet with throat microphone TH-4L-S, TH-4L-W, TH-4L-S-C, TH-4L-W-C, TH-4L-S-AC, TH-4L-W-AC

Description: external communication device of public address substations to conduct talk-back communication in environment of normal noise level.

Features:

- freedom to move;
- PTT switch type;
- may be connected to telephones and commutator telephones;
- CE type cord may be used;
- summer and winter types.
- cable TH-4L-S, TH-4L-W with bare ends;
- cable TH-4L-S-C, TH-4L-W-C with plug connector;
- cable TH-4L-S-AC, TH-4L-W-AC with angle plug type connector.

Technical specifications:

- operating frequency range: 300...3400 Hz;
- noise stability at acoustic max. 133 dB: at least 16 dB;
- word intelligibility at acoustic noise max. 133 dB: at least 94 %;
- operating temperature: -40 °C...+55 °C;
- IP rating: IP56;
- weight of intercom helmet:
 - summer, max. 0.95 kg;
 - winter, max. 1.05 kg.

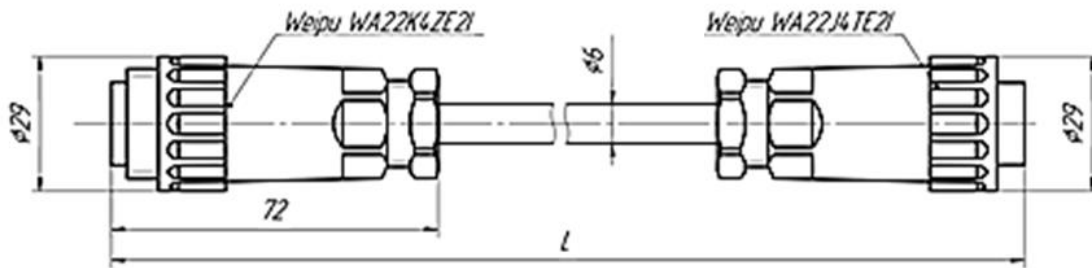

Kod	L, m	Weight
CE-15	15	0,093
CE-3	3,0	0,185
CE-5	5,0	0,240
CE-7	7,0	0,314
CE-10	10,0	0,450
CE-15BE	15	0,063
CE-3BE	3,0	0,125
CE-5BE	5,0	0,210
CE-7BE	7,0	0,294
CE-10BE	10,0	0,420
CE-15AC	15	0,083
CE-3AC	3,0	0,145
CE-5AC	5,0	0,230
CE-7AC	7,0	0,314
CE-10AC	10,0	0,440

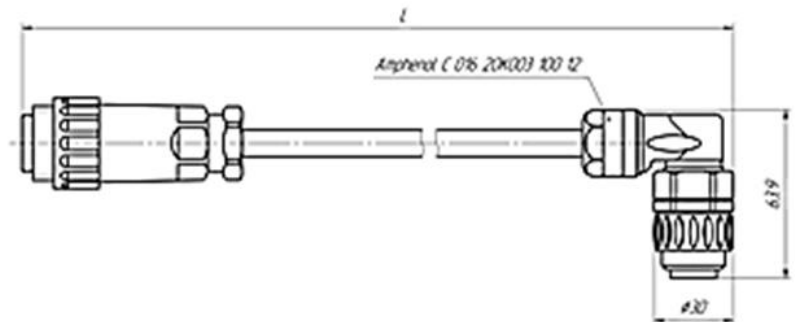

Cord CE

Description: to extend standard cord of external communication devices.

Features:

- cable ends CE-1.5, CE-3, CE-5, CE-7, CE-10: plug connector;
- cable ends CE-1.5BE, CE-3BE, CE-5BE, CE-7BE, CE-10BE: bare (crimped);
- cable ends CE-1.5AC, CE-3AC, CE-5AC, CE-7AC, CE-10AC: angle plug connector.

Technical specifications:

- IP rating: IP56;
- operating temperature: $-40\text{ }^{\circ}\text{C} \dots +55\text{ }^{\circ}\text{C}$.

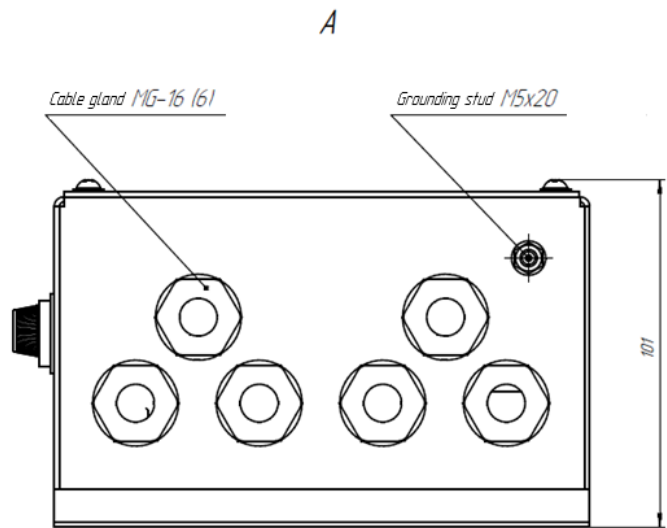
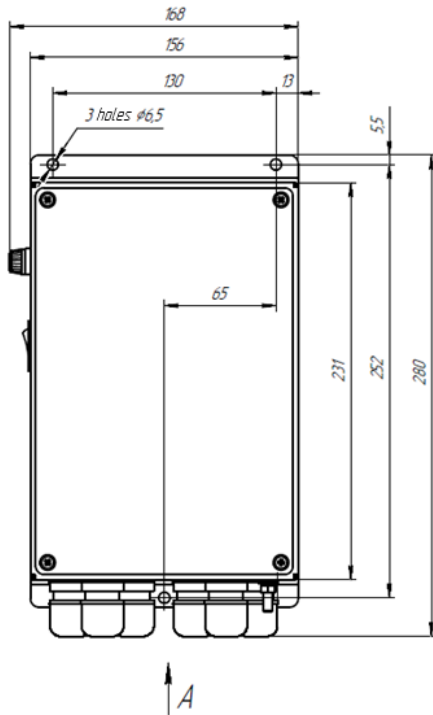

Power supply unit PS-103

Description: Power supply unit PS-103 designed to power with unregulated DC voltage 24 V to different shipborne and industrial equipment.

Features:

- contacts to connect external signaling unit (power failure signaling);
- galvanic isolation of output power from power mains;
- integrated automatic load switch to standby power source.

Technical specifications:

- power supply: 110 V or 220 V AC 50 (60) Hz;
- output voltage: 24 V DC;
- terminals to connect load: three;
- rated load current: 8 A;
- rated power: 192 W;
- operating temperature: -20 °C...+55 °C;
- IP rating: IP22;
- weight: 5.0 kg.

Mounting type: wall.

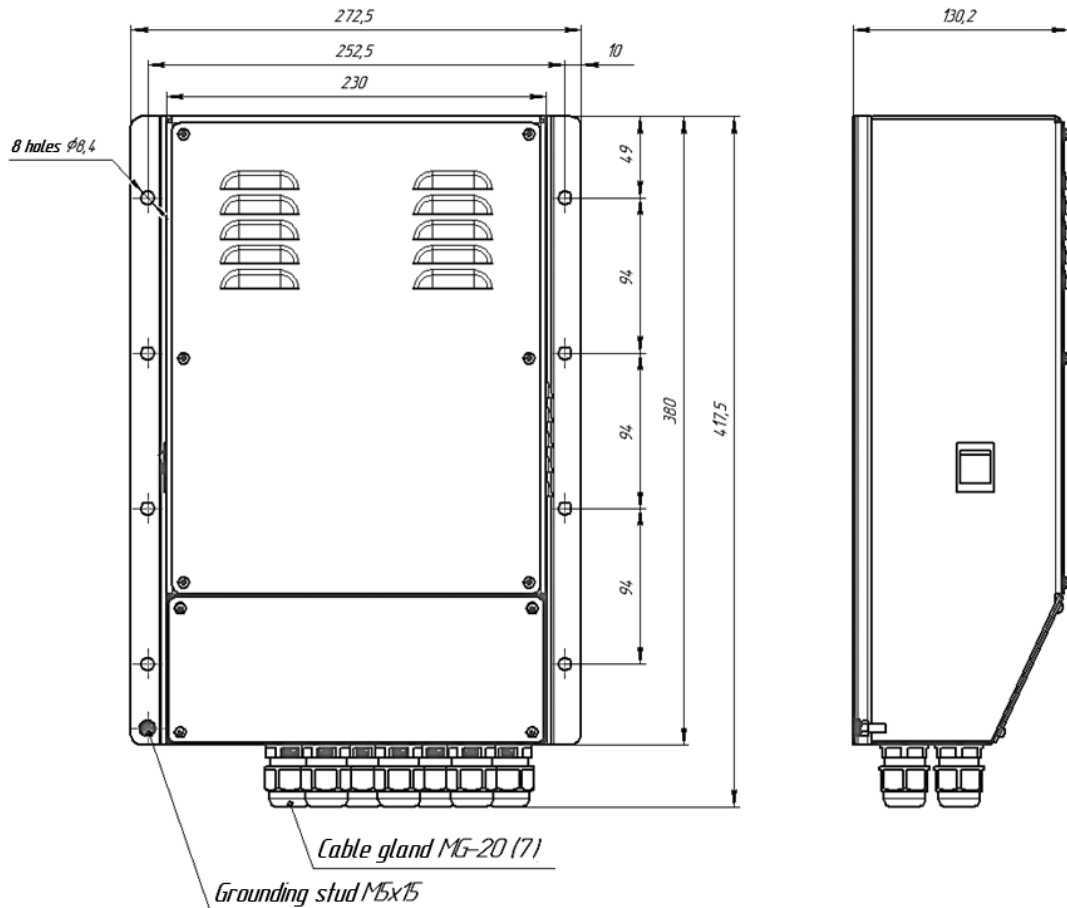

Power supply unit PS-103-20

Description: Power supply unit PS-103-20 designed to power with unregulated DC voltage 24 V to different shipborne and industrial equipment.

Features:

- contacts to connect external signaling unit (power failure signaling);
- galvanic isolation of output power from power mains;
- integrated automatic load switch to standby power source.

Technical specifications:

- power supply: 110 V or 220 V AC 50 (60) Hz;
- output voltage: 24 V DC;
- terminals to connect load: four;
- rated load current: 20 A;
- rated power: 500 W;
- power consumption: 600 W;
- operating temperature: $-20 \dots +55$ °C;
- IP rating: IP22;
- weight: 10.0 kg.

Mounting type: wall.

APPENDIX C

SET OF OPERATION AND MAINTENANCE DOCUMENTS

Table C.1 – Set of operation and maintenance documents

Name	Identifier	Note
List of System elements BTS-1006 for order № ...	List of SC	One per object
Electrical diagram for System BTS-1006 for order № ...	Electric diagram Э4 (Э5, Э6)	* One per object
Battery less communication equipment BTS-1006. Operating manual	Operating manual	One per object
Battery less communication equipment BTS-1006. Certificate	Certificate	** One per object
Battery less communication equipment BTS-1006. SPTA kit list	Settings instructions	*** One per object
Register certificate	—	**** One per object
<p>* Developed (if necessary) according to Technical description to assign System to particular object and delivered to ship constructor (customer)</p> <p>** Delivered on request.</p> <p>*** Delivered if SPTA is ordered.</p> <p>**** Delivered with order.</p> <p>Note – Additionally to current documents or in place of the documents, documents of another assignment or type may be delivered</p>		

APPENDIX D SETTINGS OF SC

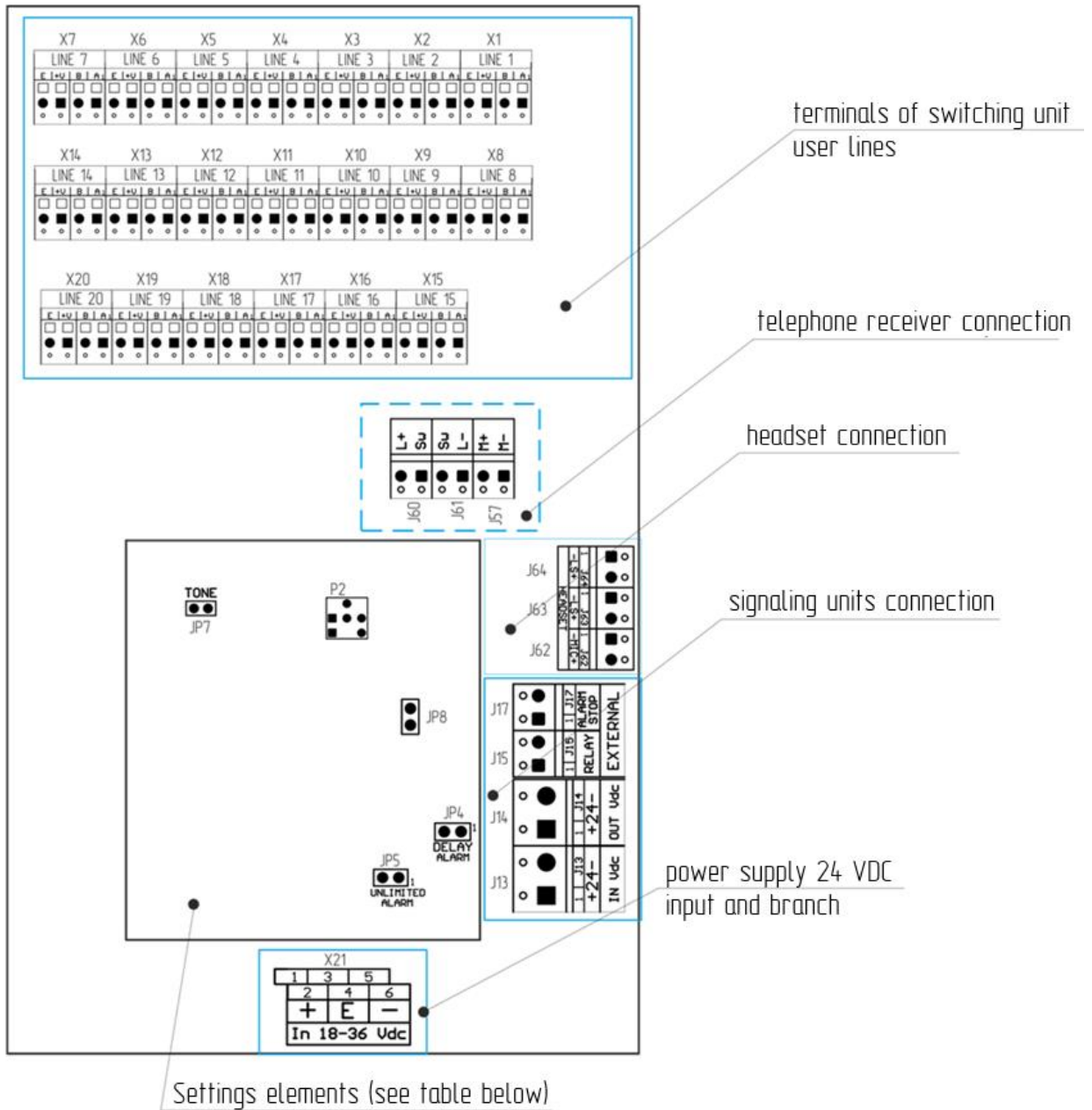

JP7	Settings of call signal frequency
P2	Settings of telephone receiver speaker volume
JP8	To control relay unit and alarm unit
JP4, JP5	To select operation mode of signaling units

Figure D.1 – Commutator telephones PH2-12C, PH2-20C.
Layout and assignment of terminals. Controls.

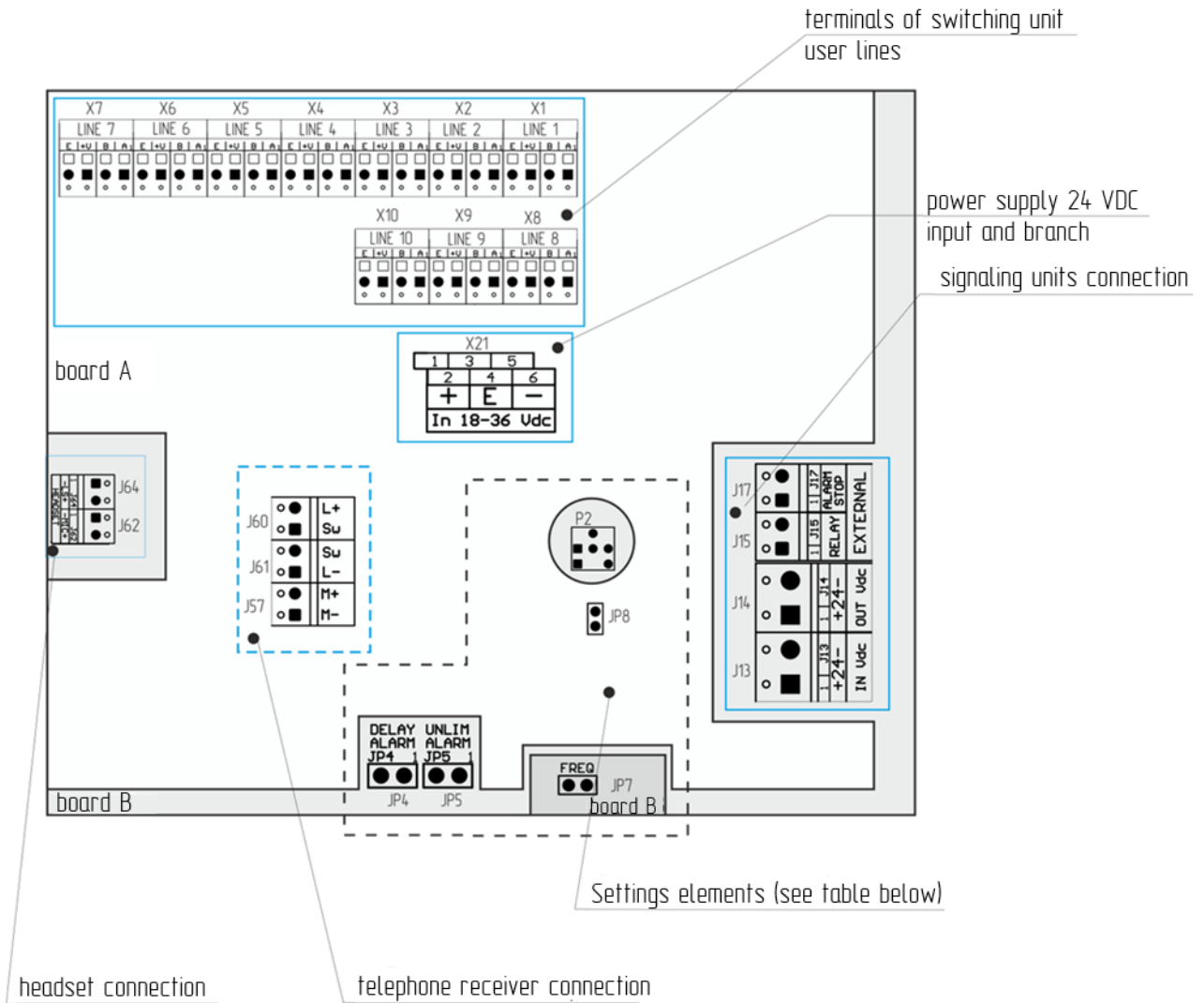

JP7	Settings of call signal frequency
P2	Settings of telephone receiver speaker volume
JP8	To control relay unit and alarm unit
JP4, JP5	To select operation mode of signaling units

Figure D.2 – Commutator telephones PH2-5C, PH2-10C. Layout and assignment of terminals. Controls.

Table D.1 – Settings of telephones and commutator telephones

Settings element	Assignment	Description	
P2	To adjust volume of incoming voice communication	Trimming resistor controls volume of incoming voice communication (sound in telephone receiver) from min. to max. value	
JP4, JP5	To set call mode	a) jumper JP5 is set – call signaling will last unless «Reset call» button is pressed; b) jumper JP4 is set – call signaling will last for 10-12 sec after the call is finished; c) jumpers JP4 and JP5 are not set – call signaling will last unless a calling user finishes the call; d) jumpers JP4 and JP5 are set – call signaling will last unless «Reset call» button is pressed	
JP7	To set call signal	Jumper not set	Call frequency – 4.5 Hz (jumper not set) (short interruptions)
		Jumper set	Call frequency – 3 Hz (jumper set) (long interruptions)
JP8	To control relay unit	To connect signaling unit type RBWSB, set the jumper	

Table D.2 – Settings and assignment of relay unit elements

Element	Settings type	Description
JP1	To set call mode	a) jumper JP1 is set – call signaling will last unless «Reset call» button is pressed; b) jumper JP2 is set – call signaling will last for 10-12 sec after the call is finished; c) jumpers JP1 and JP2 are not set – call signaling will last unless a calling user finishes the call; d) jumpers JP1 and JP2 are set call signaling will last unless «Reset call» button is pressed

Table D.3 – System settings when delivered from the Manufacturing plant

Element	Position	Settings
JP8	Not set	Control over relay unit is switched off
JP 7	Set	Frequency of signal interruption 3 Hz
JP 4	Not set	Incoming call signal will last unless the calling user finishes the call
JP5	Not set	

APPENDIX E CONNECTION OF THE SC

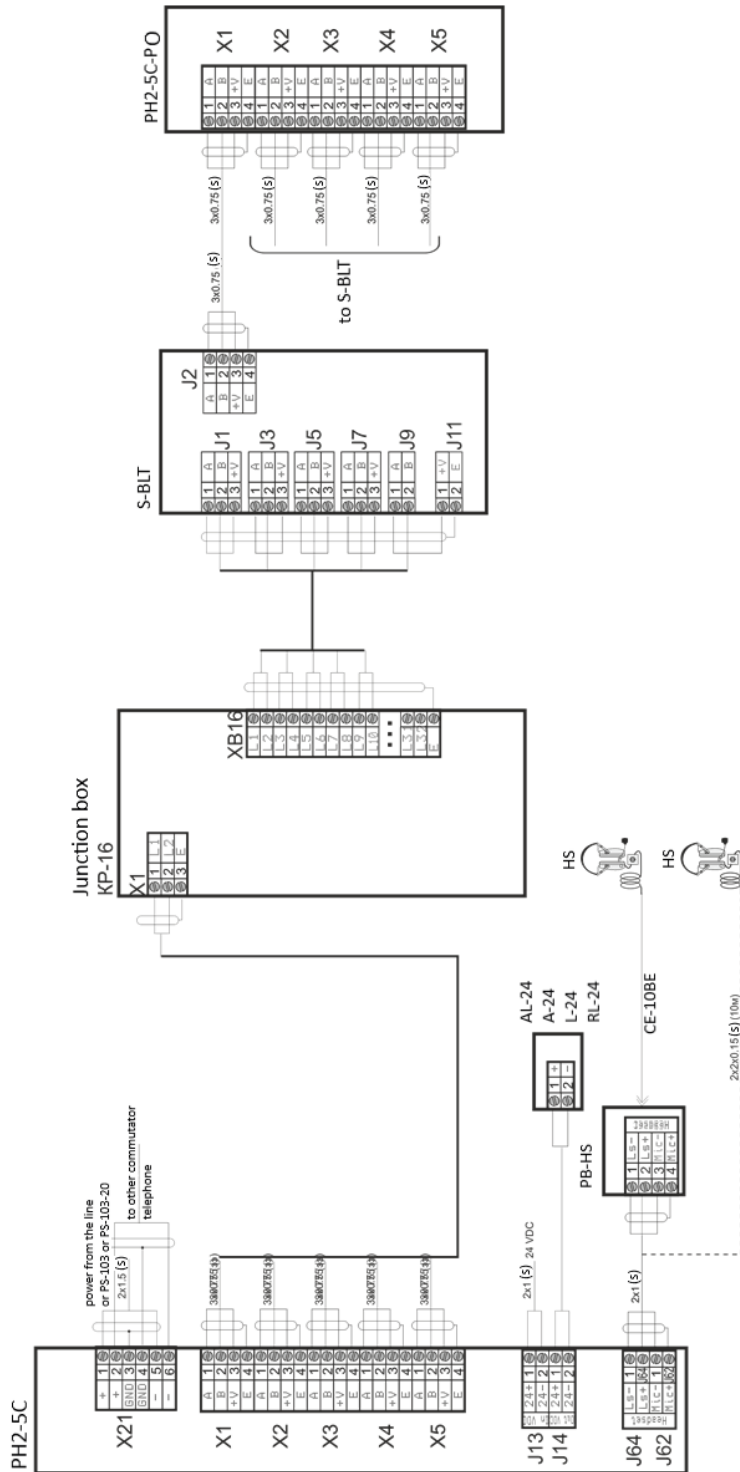

Figure E.1 – Connection of commutator telephone PH2-2C and portable commutator telephone PH2-5C-PO

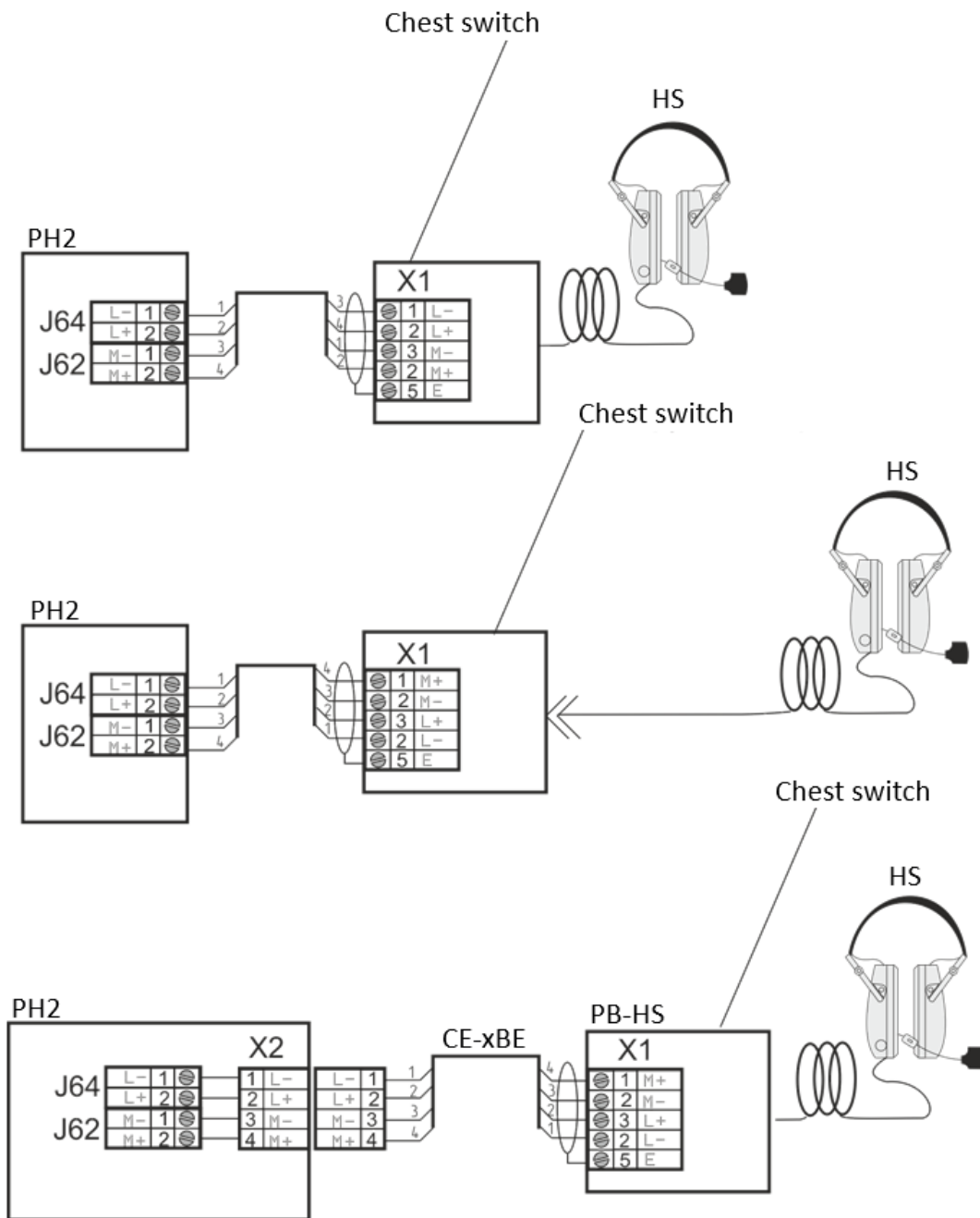

Figure E.3 – Connection of external communication devices

Table E.1 – Description of HS headset wires with bare ends

Pos.	Description	Wire colour
1	M-	brown
2	L+	(yellow shield)
3	L-	yellow
4	M+	black

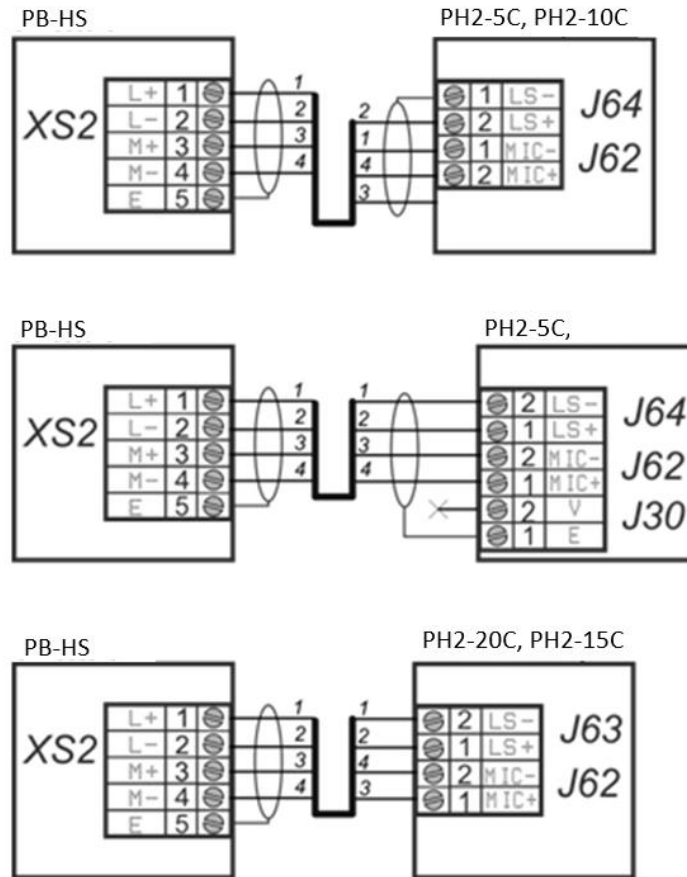

Figure E.4 – Connection of socket PB-HS

APPENDIX F THE SCOPE OF DELIVERY

Standard scope of delivery includes:

Battery less telephone system BLTS-1006	1 set*
Operation and technical documents	1 set**
SPTA kit	1 set***

* The System's scope of delivery is specified at the stage of project design in the order list (or stated in Supply contract), see 1.3.

** Documents are delivered according to the list, see Appendix C.

*** Basic SPTA kit is delivered according to the list, see Appendix A; additional SPTA kit is specified in the Contract.