

# **Power Supply unit PS-103, PS-103-20**

Operating manual

**Table of contents**

<b>INTRODUCTION .....</b>	<b>3</b>
<b>1 DESCRIPTION AND OPERATION OF THE PRODUCT .....</b>	<b>4</b>
1.1 Description .....	4
1.2 Main technical specifications .....	4
1.3 Operation of the Product .....	4
1.4 Measurement tools, instruments and consumables .....	9
1.5 Marking and sealing .....	9
1.6 Packaging .....	9
<b>2 USAGE OF THE PRODUCT .....</b>	<b>10</b>
2.1 Operational constraints.....	10
2.2 Usage preparations .....	10
<b>3 TECHNICAL SERVICE.....</b>	<b>12</b>
3.1 General description .....	12
3.2 Safety features .....	12
3.3 Maintenance routine.....	12
3.4 Preservation.....	13
<b>4 CURRENT REPAIR OF THE PRODUCT.....</b>	<b>14</b>
4.1 General description .....	14
4.2 Safety features .....	14
4.3 Current repair of the Product.....	14
<b>5 STORAGE .....</b>	<b>15</b>
<b>6 TRANSPORTATION.....</b>	<b>16</b>
<b>7 DISPOSAL.....</b>	<b>17</b>
<b>ANNEX A (MANDATORY) OUTLINE AND INSTALLATION DIMENSIONS OF THE PRODUCT.....</b>	<b>18</b>

## **INTRODUCTION**

This operating manual (hereinafter referred to as OM) is intended to describe the structure, operating principles, technical specifications and service of unregulated power supply units PS-103 and PS-103-20 (hereinafter referred to as the Product, PSU).

In addition to the instructions given in this document, the safety regulations and rules applicable in the field shall be observed.

Only those who have read and understood this document and those who have had special training shall be permitted to operate with the PSU according to the applicable regulations.

### **Terms and abbreviations:**

PSU – power supply unit;

SC – short circuit;

OM – operating manual;

TS – technical service;

CL –check list;

SB – storage battery;

LFSG – large fine-pored silica gel granular.

## 1 DESCRIPTION AND OPERATION OF THE PRODUCT

### 1.1 DESCRIPTION

The PSU is designed to operate with single phase AC mains, frequency 50 (60) Hz, voltage 220 V (110 V at option) and to provide unregulated power of 24V DC for various shipboard and industrial equipment.

### 1.2 MAIN TECHNICAL SPECIFICATIONS

Technical specifications of PSU are represented in table 1.

Table 1 – Main technical specifications of the Product designs

Parameter	Value	
	PS-103	PS-103-20
Input voltage AC 50 (60) Hz, V	220 (110 at option) $\pm$ 10 %	
Standby power from batteries, V DC	24	
Output voltage, V DC	18 to 31	
Rated load current, A	10	20
Rated power, W	output	400
	consumed	450
Alarm output	«dry contact» Normally closed Normally opened	«dry contact» Normally opened
Number of connected loads	3	4
Weight, kg	4.4	9.3
Protection degree	IP22	
Operating temperature, °C	-15 to +55	
Temperature limit, °C	-60 to +70	
Mounting type	wall	

### 1.3 OPERATION OF THE PRODUCT

#### 1.3.1 General information

The Product is produced in metal casing which has a special mount for mounting on a vertical bulkhead. There is a piano type switch (to switch the power on / off) on the casing side as well as main power LED which glows green if the switch is in ON position.

### 1.3.2 Controls and indication

The layout of the PSU's key functional elements, controls and indication are represented in Figures 1, 2.

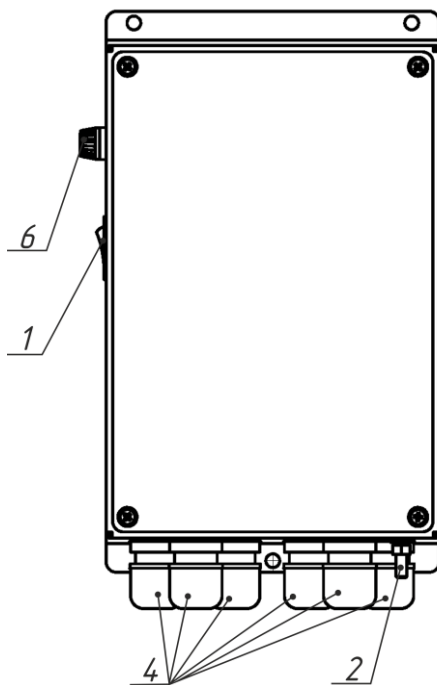

Figure 1 – Functional elements, controls and indication of PS-103

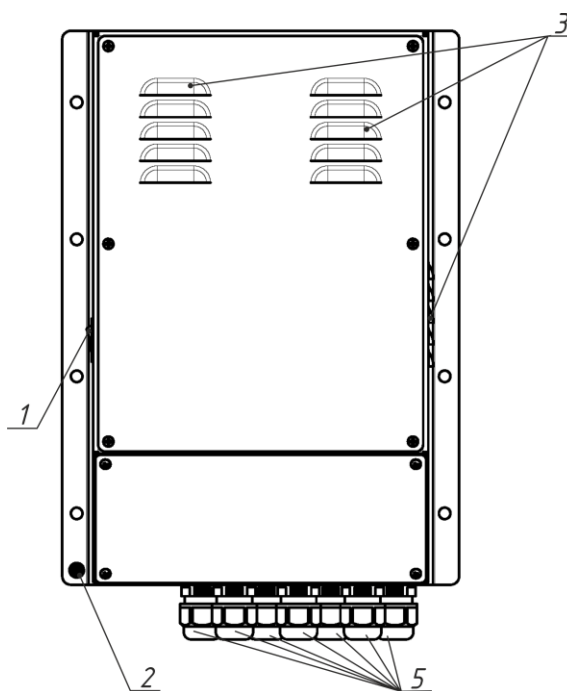

Figure 2 – Functional elements, controls and indication of PS-103-20

Description of the functional elements, controls and indication is represented in table 2.

Table 2 – Description of the functional elements, controls and indication of the PSU

Tag №	Element	Type, standard size, identifier	Description
1	Piano type switch	–	Piano type switch to turn power on (off), with backlight
2	Ground stud	M5x20	Key element of the unit grounding point
3	Air grille	–	Cooling of the unit
4	Cable gland	MG-16	Cable gland / input
5		MG-20	
6	Fuse holder	FH-02	Protection of input mains from overload and SC of the unit

Note – Tag № are shown in Figures 1, 2.

### 1.3.3 Connection of the Product

The main and standby power is supplied to PS-103 and PS-103-20 terminals; standby power is supplied from backup power sources to provide uninterruptible operation of the equipment connected to the PSU (see figures 3, 4).

**Caution!** The PSU shall not be used to charge SB!

The closing or opening of dry contacts (depending on the connection type) occurs in case of main power failure, that allows for using the PSU together with connected alarm unit, AU-106 (AU-206) type, as a signaling unit of voltage loss in power mains or PSU malfunction.

#### 1.3.3.1 Connection of PSU PS-103

The connection diagram and description of connector terminals of PS-103 are represented in Figure 3 and in table 3. Pins 2 and 3 of connector XS1 are closed if the main power is available; if the main power fails, the pins are opened.

Pins 1 and 2 of connector XS1 are opened if the main power is available; if the main power fails, the pins are closed.

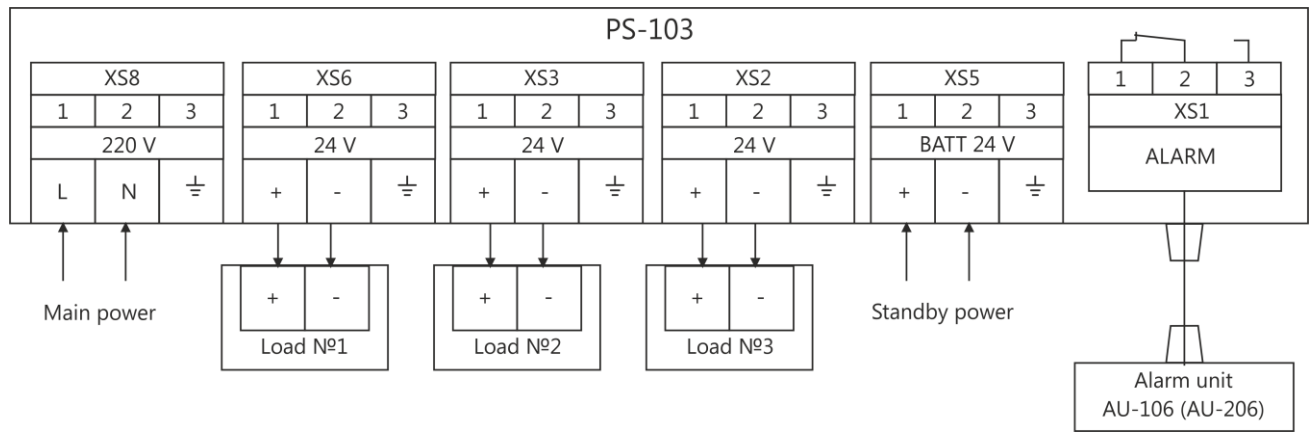

Figure 3 – Connection diagram of PS-103

Table 3 – Description of connector terminals of PS-103

Connector	Terminal №	Description
XS1	1	Alarm unit connection
	2	
	3	
XS5	1	+ 24 V DC (SB connection)
	2	0 V
	3	Ground connection
XS2	1	+ 24 V DC (to connect load №3)
	2	0 V
	3	Ground connection
XS3	1	+ 24 V DC (to connect load №2)
	2	0 V
	3	Ground connection
XS6	1	+ 24 V DC (to connect load №1)
	2	0 V
	3	Ground connection
XS8	1	110; 220 V, 50 Hz
	2	Neutral wire connection
	3	Ground connection

### 1.3.3.2 Connection of PSU PS-103-20

The connection diagram and description of connector terminals PS-103-20 are represented in Figure 4 and in table 4.

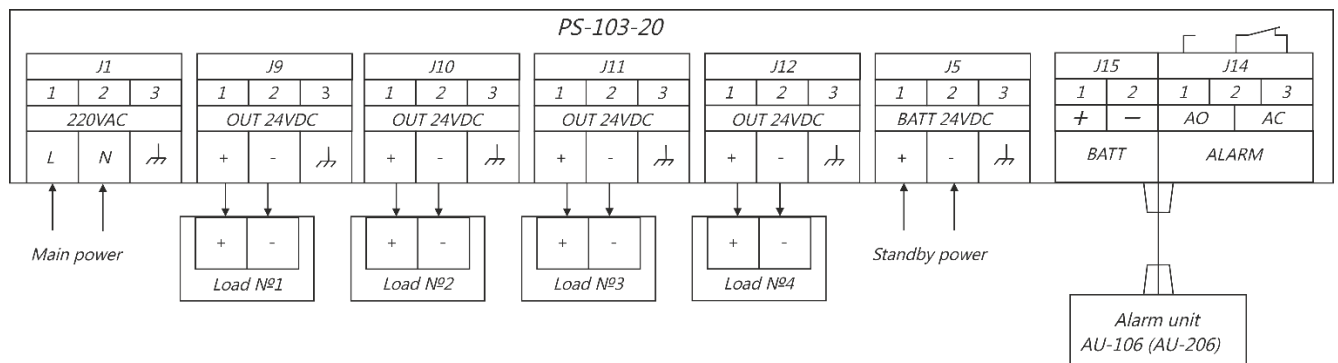

Figure 4 – Connection diagram of PS-103-20

Table 4 – Description of connector terminals PS-103-20

Connector	Terminal №	Description
J1	L	110; 220 V, 50 Hz
	N	Neutral wire connection
	⏚	Ground connection
J9	+	+ 24 V DC (to connect load №1)
	-	0 V
	⏚	Ground connection
J10	+	+ 24 V DC (to connect load №2)
	-	0 V
	⏚	Ground connection
J11	+	+ 24 V DC (to connect load №3)
	-	0 V
	⏚	Ground connection
J12	+	+ 24 V DC (to connect load №4)
	-	0 V
	⏚	Ground connection
J5	+	+ 24 V DC (SB connection)
	-	0 V
	⏚	Ground connection
J14, J15	ALARM	Alarm unit connection



## 1.4 MEASUREMENT TOOLS, INSTRUMENTS AND CONSUMABLES

Amount of consumables required for TS is represented in table 5.

Table 5 – Amount of consumables required for TS

Name and identifier of consumables	Amount of consumables	Note
Cleaning cloth	0.10 kg	To clean surfaces of the unit
Rectified hydrolytic technical ethyl alcohol	0.01 l	1 To clean severe contamination from surfaces of the unit 2 To clean by rubbing surfaces with paint coating damage
Varnish	0.05 kg	To cover surfaces of the unit in case of paint coating damage
Abrasive cloth	0.06 x 0.06 m	To polish surfaces of the unit in case of paint coating damage

## 1.5 MARKING AND SEALING

The nameplates are located on the Product, where the user can find the name, serial number, date of manufacturing, weight, protection degree, output voltage and output power of the Product.

The sealing of the Product is not provided.

## 1.6 PACKAGING

At the time of delivery the Product is packed in a corrugated board box and inner packaging ensuring its transportation and storage at the warehouse.

Transport packaging is also used as a returnable packaging for transportation of the Product to the repair location and back.

The sealing of transport packaging is not provided.

## 2 USAGE OF THE PRODUCT

### 2.1 OPERATIONAL CONSTRAINTS

The Product shall be installed only according to its outline dimensions.

**Caution!** Distance between the installation site and magnetic compass shall not be less than 1 m

Select the installation site in compliance with operational constraints (operating temperature and protection degree – IP).

### 2.2 USAGE PREPARATIONS

#### 2.2.1 Safety features

While preparing the Product for operation, check it visually after unpacking; mechanical damage shall be absent.

Connection to power mains shall be provided only in compliance with input power requirements.

Before connecting the Product shall be switched off and have a proper grounding.

While using the Product the staff shall follow “The technical rules for operation of electric installation” and “Safety rules for operation of electric installation” while testing electrical circuits and insulation resistance.

#### 2.2.2 Visual check procedure

Before switching the units on, the staff shall:

- observe visually the cable integrity and initial position of the controls on the front panels;
- check the absence of dust and dirt on the Product casing; clean with a soft cloth if necessary;
- check that cable connectors are securely connected to the Product.

#### 2.2.3 Directions for switching on

While connecting the PSU and preparing it for operation follow the steps below:

- transfer circuit breakers of main power and PSU on the power mains switchboard to “OFF” position;
- connect deenergized cable of main power and SB to input terminals;
- transfer circuit breakers of main power and PSU on the power mains switchboard to “ON” position;

- transfer a circuit breaker inside the Product casing to “ON” position (only for PS-103-20);
- transfer a piano type switch to “ON” position;
- check that the Product is connected properly and main power is available by green LED glowing on the piano type switch, located on the Product casing, dry contact alarm shall be absent;
- using voltmeter measure an output voltage on the connector pins intended for load connection; it shall comply with the range represented in table 1. If voltage on the output terminals doesn’t comply with the rated value, the Product is considered to be not applicable for operation. If this occurs, contact the Manufacturer;
- transfer piano type switch to “OFF” position. If you use PS-103-20, additionally transfer a circuit breaker inside the casing to “OFF” position;
- connect the load and alarm unit AU-106 (AU-206);
- transfer piano type switch to “ON” position. If you use PS-103-20, additionally transfer a circuit breaker inside the casing to “ON” position; check load operation.

To switch the PSU off, provide the following steps:

- transfer piano type switch on the casing to “OFF” position. If you use PS-103-20, additionally transfer a circuit breaker inside the casing to “OFF” position; also transfer circuit breakers of main power and SB on the power mains switchboard to “OFF” position;
- disconnect the cables.

### 3 TECHNICAL SERVICE

#### 3.1 GENERAL DESCRIPTION

The TS shall be provided by the staff acquainted with its composition, structure and operation features.

In order to provide safe and reliable operation for the Product, the staff shall maintain technical service № 1 (hereinafter – TS-1) – semi-annual TS;

TS-1 shall be provided by the staff on the running equipment.

#### 3.2 SAFETY FEATURES

While maintaining the TS, observe 4.2.

#### 3.3 MAINTENANCE ROUTINE

The list of works for all types of TS is given in table 6. Maintenance routine procedure is given in CL, represented in tables 7, 8.

Table 6 – List of works by TS types

CL №	Work	Type of TS
		TS-1
1	Visual check of the Product	+
2	Test for the Product operability	+
Note: “+” – work is obligatory.		

Table 7 – CL № 1. Visual check of the Product

To be done	Routine	Man-hours per 1 Product
Visually examine the Product	1 check completeness and appearance of the Product; mechanical damage, paint defects must be absent; marking plates shall be present; legends are to be read easily. 2 clean up the Product surfaces with clean cloth; 3 remove severe contamination, parts of corrosion, oil spots from the metal surfaces – using ethyl alcohol, avoiding its penetration inside the Product; all surfaces clean dry by clean cloth and dry up; 4 If varnish paint coating is damaged, polish it with sand paper, then clean with alcohol-soaked cloth, cover with varnish and dry up	1 person 5 mins
Check reliability of cable and bus connection to the Product	1 check that connectors and attaching screws are fastened tight; provide further fastening if needed. 2 check the cable integrity (mechanical damage shall be absent) within visibility	1 person 5 mins

Table 8 – CL № 2. Operability check of the Product

<b>To be done</b>	<b>Routine</b>	<b>Man-hours per 1 Product</b>
Check operability of the Product	1 switch on power supply; 2 Power LED on the piano type switch (located on the casing side) shall glow green; 3 take the voltage on the load terminals	1 person 5 mins

### 3.4 PRESERVATION

The Product and set of operational documents are stored in preserved condition in Manufacturer's packaging boxes.

The time of represervation – 2 years from the Manufacturer's commissioning.

The preservation is done in full terms, for 2 years, applying protection and packaging.

The represervation is done in heated rooms in the same order as the preservation.

The represerved Product and documents are placed in package.

## 4 CURRENT REPAIR OF THE PRODUCT

### 4.1 GENERAL DESCRIPTION

Operability of the Product is indicated by presence of piano type switch backlight, located on the casing.

To diagnose the problem, see table 9.

If you cannot diagnose the problem, contact the Manufacturer's service centre.

### 4.2 SAFETY FEATURES

Any repair works must be provided by personnel examined and received proper qualifications in the area of the occupational safety.

Check grounding of the PSU before providing any repair works.

It is **PROHIBITED** to put a poster “DO NOT switch on! Under Operation!”, when power supply switch is in OFF position.

Replacing damaged parts, boards, modules is **PROHIBITED** if power supply of the repaired unit is on

Installation, aligning and repair works are **PROHIBITED** in the room, where less than 2 people are present

### 4.3 CURRENT REPAIR OF THE PRODUCT

The list of malfunctions that can be eliminated by own employees is represented in table 9.

The repair of other malfunctions can be done only by Manufacturer's specialists or Manufacturer's authorized representatives.

Table 9 – The list of possible malfunctions and troubleshooting

Malfunction	Possible reasons	To be done
Voltage is absent on the PSU output when SB is switched off	Power supply voltage is absent (piano type switch doesn't glow)	Check the power cable connection Supply the power (a circuit breaker on the power mains switchboard might be probably switched off)
	Fuse malfunction (PS-103)	Replace the fuse
	Circuit breaker is switched off (PS-103-20)	Take off the PSU cover, switch on the circuit breaker inside the PSU

## **5 STORAGE**

The units must be stored in packaging inside areas complying with the required storage conditions (+ 5 to + 40 °C) with the concentration of dust, oil, moisture and aggressive impurities in the air within the required limits for the working areas of production facilities.

After storage or transportation of the device below + 10 °C, it must be unpacked only in heated premises and left in normal climate conditions for 12 hours beforehand.

## 6 TRANSPORTATION

The Product must be transported in the Manufacturer's transportation package in closed means of transport.

Types of shipment:

- motor vehicle and railroad transportation in closed means of transport (covered cars, multipurpose containers);
- air transportation (in sealed and heated compartments);
- sea transportation (in dry service premises).

The units must be transported in compliance with transportation rules applicable for each means of transport.

During loading / unloading operations and transportation, the requirements indicated on warning labels on the boxes / packaging must be observed, and no impacts are permitted since they can affect the safety and performance of the Product.

Inside the means of transport, the packed device must be firmly secured / fastened.



## 7 DISPOSAL

New equipment, the parts of the Product damaged during operation, and any overage equipment must not be disposed as standard household wastes, since they contain the materials suitable for re-use.

Decommissioned and non-used components of the Product must be delivered to a special waste disposal center licensed by local authorities. You can also send an overage equipment / unit to the manufacturer for its further disposal.

Proper disposal of Product components allows avoiding possible negative environmental and health impacts, and it also allows for proper restoration of components with substantial energy and resources saving.

**During operation and upon completion of its service life, the equipment is not hazardous for health and environment**

**This units must be disposed according to applicable rules for electronic devices in the country of the buyer**



**Any products marked with a crossed trash bin must be disposed separately from standard house-hold wastes**

**ANNEX A  
(MANDATORY)  
OUTLINE AND INSTALLATION DIMENSIONS OF THE PRODUCT**

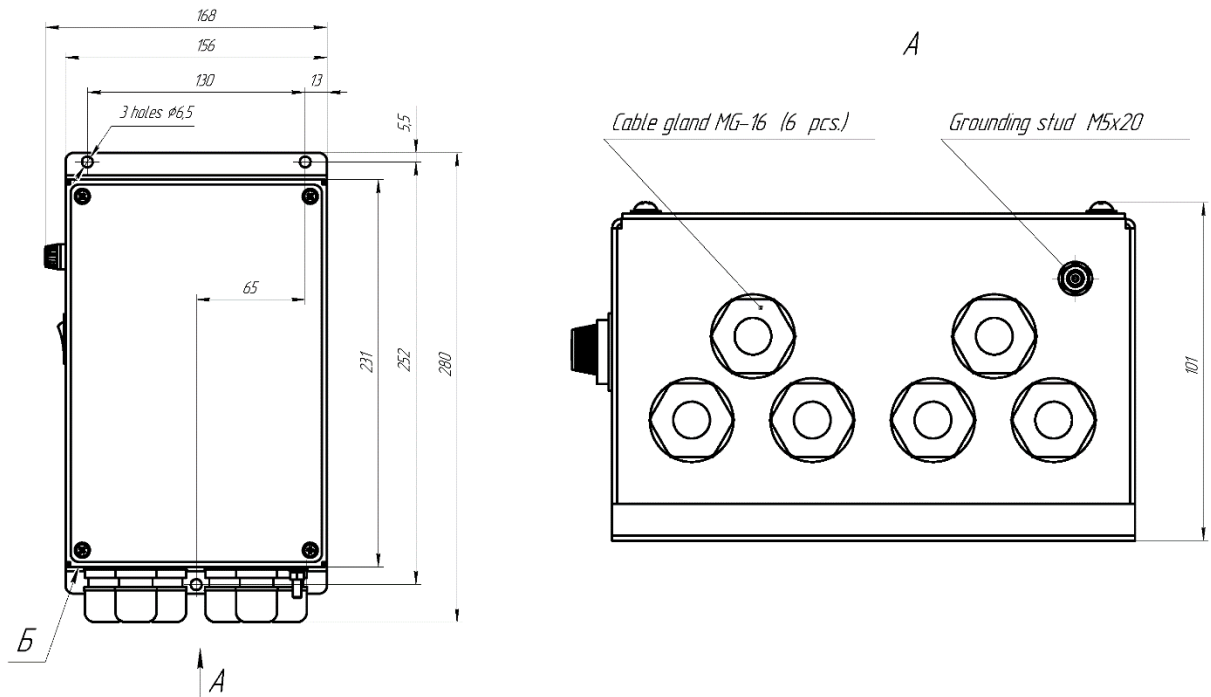

Figure A.1 – Outline and installation dimensions of PS-103

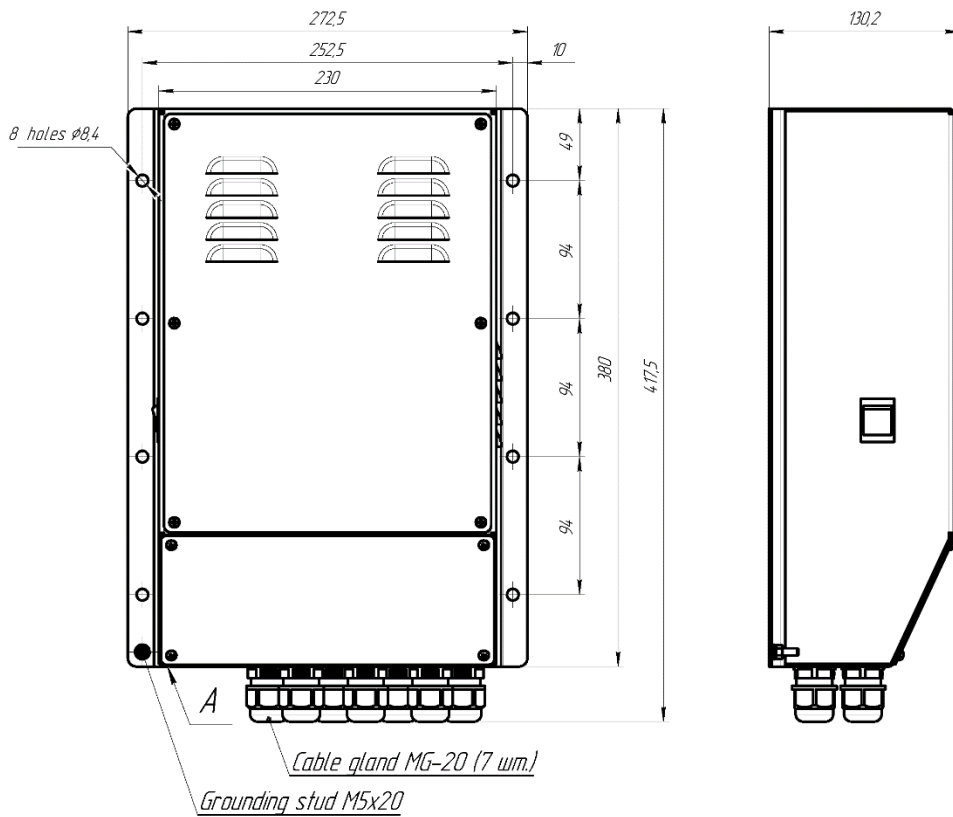

Figure A.2 – Outline and installation dimensions of PS-103-20