

POWER SUPPLY UNIT PS-203-50

Operating manual

Table of contents

| | |
|--|-----------|
| INTRODUCTION | 3 |
| 1 DESCRIPTION AND OPERATION OF THE PRODUCT | 4 |
| 1.1 Description | 4 |
| 1.2 Technical specifications | 4 |
| 1.3 Structure and operation of the Product..... | 4 |
| 1.4 Measurement instruments, tools and appliances | 7 |
| 1.5 Marking and sealing | 7 |
| 1.6 Packaging | 7 |
| 2 INTENDED USE OF THE PRODUCT | 8 |
| 2.1 Operational limitations | 8 |
| 2.2 Usage preparations | 8 |
| 3 TECHNICAL SERVICE OF THE PRODUCT..... | 10 |
| 3.1 General description | 10 |
| 3.2 Safety features | 10 |
| 3.3 Maintenance routine | 10 |
| 3.4 Preservation..... | 11 |
| 4 CURRENT REPAIR OF THE PRODUCT | 12 |
| 4.1 General description | 12 |
| 4.2 Safety features | 12 |
| 4.3 Current repair | 12 |
| 5 STORAGE | 13 |
| 6 TRANSPORTATION..... | 14 |
| 7 DISPOSAL..... | 15 |
| 8 WARRANTY..... | 16 |
| APPENDIX A (MANDATORY) REGULATORY DOCUMENTS | 17 |

INTRODUCTION

This operating manual (hereinafter – OM) describes composition, structure, operation and technical service of power supply units PS-203-50 type (hereinafter – the Product).

In addition to the instructions given in this document, the safety regulations and rules applicable in the field shall be observed.

Only those who have read and understood this document and those who have had special training shall be permitted to operate the Product according to the applicable regulations.

TERMS AND ABBREVIATIONS:

OM – operating manual;

SC – short circuit;

TS – technical service;

CL – check list;

PS-203-50 – power supply unit PS-203-50.

1 DESCRIPTION AND OPERATION OF THE PRODUCT

1.1 DESCRIPTION

The Product operates with single-phase AC, frequency 50 (60) Hz, voltage 110 V or 220 V. It powers different shipborne and industrial equipment with regulated voltage 12 V DC. The PS-203-50 has a function of load switch to standby power.

1.2 TECHNICAL SPECIFICATIONS

Table 1 describes technical specifications of the Product.

Table 1 – General technical specifications

| Parameter | Value |
|--|--|
| Input supply voltage, AC, frequency 50 (60) Hz, V | 110 (90 to 132)* 220 (180 to 264)* |
| Consumption current, A | 10 (115 V, 47 to 63 Hz) 6 (230 V, 47 to 63 Hz) |
| Rated output voltage, DC, V | 12 |
| Load current, A | 50 (max. 37.5) |
| Power consumption, W | 723 |
| Output power, W | 600 |
| Pulses, mV | 150 |
| Number of load terminals, pcs. | 2 |
| Protection degree | IP22 |
| Operating temperature, °C | -15 to +55 |
| Limiting temperature, °C | -60 to +70 |
| Weight, kg | 15 |
| Integrated protection | – Galvanic isolation of input and output power circuits – SC and overload |
| Mounting | wall |
| * Supply voltage range is given in parenthesis. | |

1.3 STRUCTURE AND OPERATION OF THE PRODUCT

1.3.1 The Product is manufactured in metal casing, which has a mounting to vertical bulkhead. A piano type on/off switch with a main power LED (green) is located on the casing side. The LED operates when the switch is turned to power “ON” position (Figure 1).

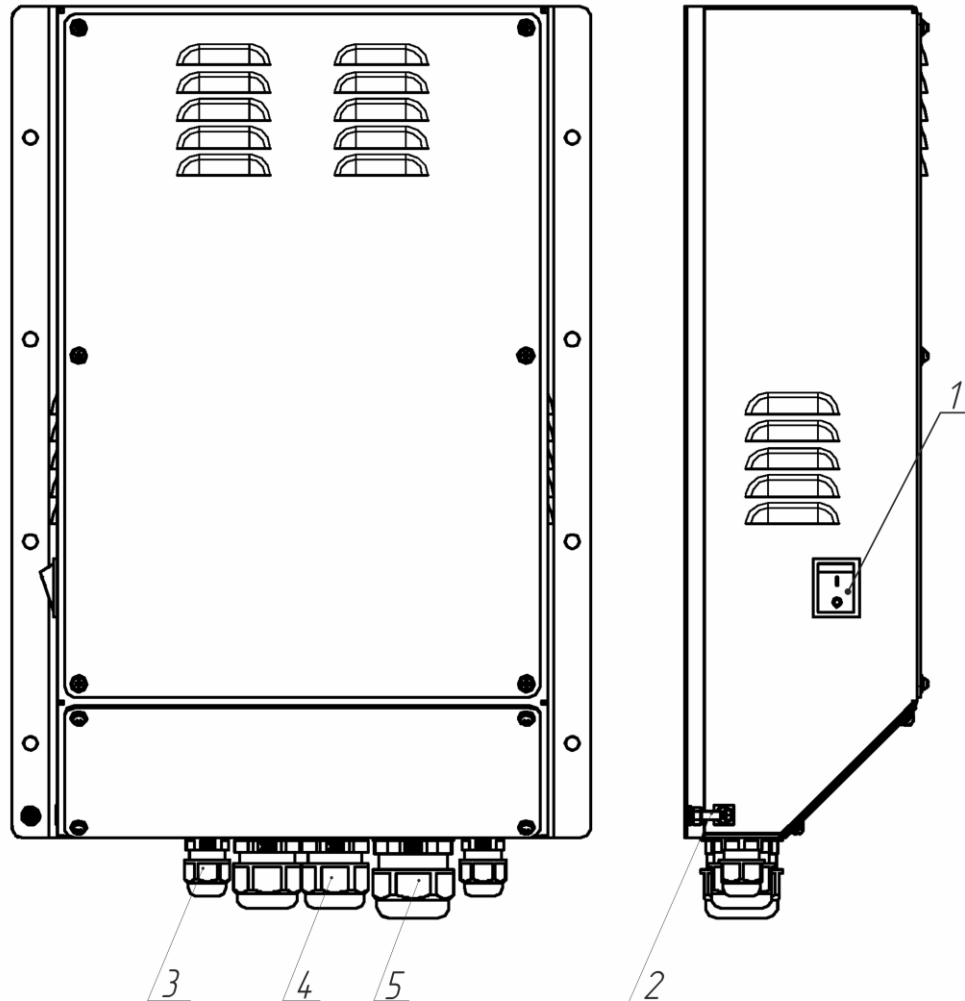

Figure 1 – The Product

Table 2 describes functional elements and controls of the Product.

Table 2 – Functional elements, controls and LED light indicators of the Product

| Nº | Element | Type, size, identifier | Description |
|----|-------------------|------------------------|---|
| 1 | Piano type switch | – | Piano type switch to switch on/off power, with backlight |
| 2 | Grounding stud | M5x20 | Main grounding element |
| 3 | Cable gland | MG-16 | Cable gland to connect input and standby power, loads and alarm |
| 4 | | MG-25 | |
| 5 | | MG-32 | |

Note – See positions (Nº) in Figure 1.

1.3.2 Power from standby sources or SB is supplied to the Product terminals ensuring uninterruptible operation of the equipment connected to the Product, see Figure 2.

Automatic standby power switching occurs in case of the Product failure and main power failure. If there is no input power, dry contacts relay actuates alarm signal-

ing. SB voltage to power external signaling unit AU-106 (AU-206) is connected to “Alarm” terminal.

Table 3 describes assignment of connector terminals.

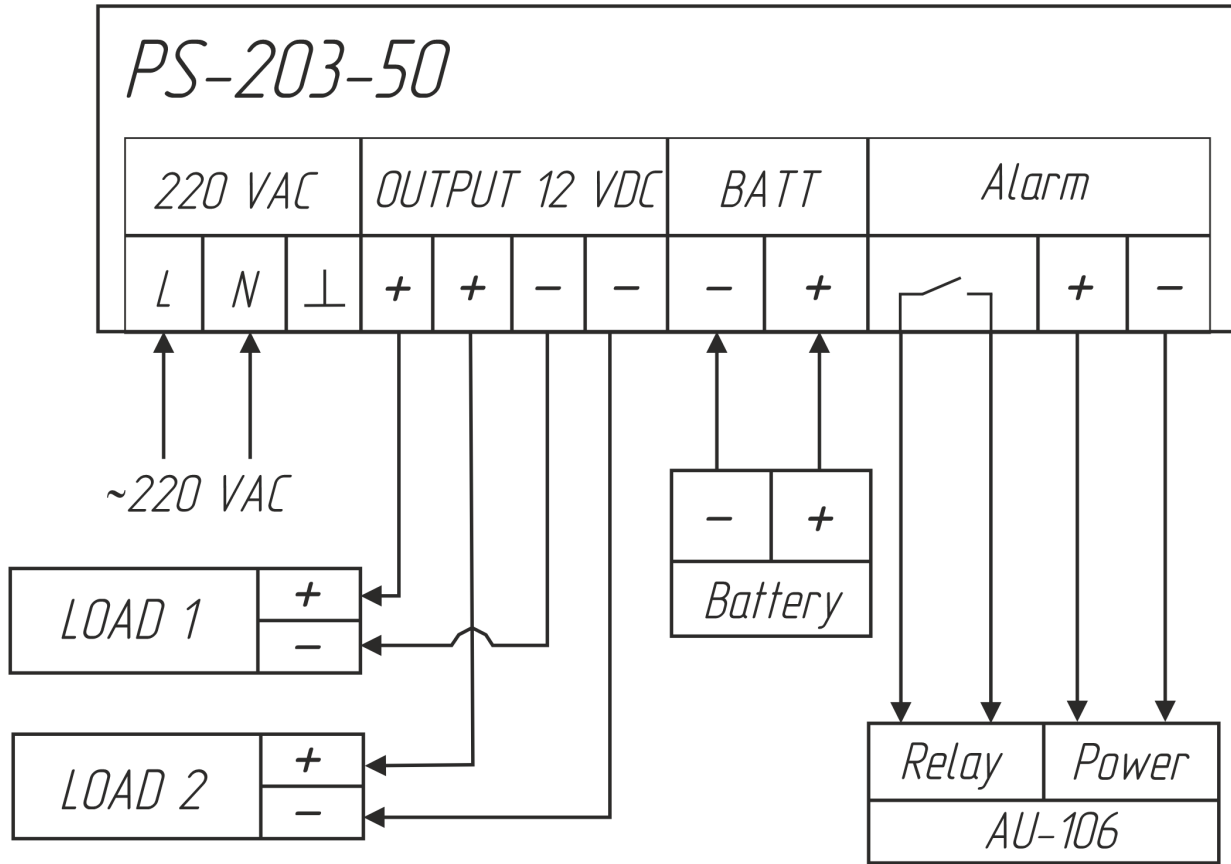

Figure 2 – Connection diagram

Table 3 – Assignment of PS-203-50 connector terminals

| Connector | Terminal № | Description |
|----------------|------------|---|
| 220 V AC | L | To connect main power |
| | N | |
| | ⊥ | |
| OUTPUT 12 V DC | + | To connect load 1 |
| | - | To connect load 2 |
| | + | |
| | - | |
| BATT | + | To connect external SB |
| | - | |
| Alarm | ⏏ | To connect relay contacts AU-106 (AU-206) |
| | + | Power 24 V DC |
| | - | |

1.4 MEASUREMENT INSTRUMENTS, TOOLS AND APPLIANCES

Table 4 below describes consumables required for the TS.

Table 4 – Consumables required for the TS

| Name and identifier of consumables | Amount of consumables | Note |
|--|-----------------------|---|
| Cleaning cloth | 0.10 kg | 1 To clean the Product surfaces – use clean cloth 2 To remove severe contamination – use cloth soaked in alcohol |
| Rectified hydrolytic technical ethyl alcohol | 0.05 l | To soak cloth when removing contamination from a screen |
| Varnish | 0.05 kg | To cover surfaces of the Product in case of paint coating damage |
| Abrasive cloth | 0.06 x 0.06 m | To polish surfaces of the Product in case of paint coating damage |

1.5 MARKING AND SEALING

The Product has a nameplate displaying a name, input and output voltage, power consumption and output power, protection degree, weight, serial number and date of manufacturing.

Sealing of the Product is not provided.

1.6 PACKAGING

When delivered, the Product is packed in a corrugated board box and inner packaging (air bubble film) ensuring its transportation and storage at the warehouse.

Transport packaging is also used as a returnable packaging for transportation of the Product to the repair location and back.

Sealing of packaging is not provided.

2 INTENDED USE OF THE PRODUCT

2.1 OPERATIONAL LIMITATIONS

Select an installation place in compliance with operational limitations (operating temperature and protection degree).

Caution! Distance between the installation site and magnetic compass shall not be less than 1 m!

2.2 USAGE PREPARATIONS

2.2.1 Safety features

While preparing the Product for operation, check it visually and make sure there is no mechanical damage.

Connect the Product to power mains only in compliance with input power requirements.

Before connection the Product shall be switched off and grounded.

While using the Product the staff shall follow “The technical rules for operation of electric installation” and “Safety rules for operation of electric installation” while testing electrical circuits and insulation resistance.

2.2.2 Visual check procedure

Before switching the SC on, the installer shall:

- a) observe visually the cable integrity and initial position of the controls;
- b) clean the SC from dust and dirt by clean soft cloth, if necessary, see Table 4;
- c) check fail-safe cable connections to the SC and their proper grounding.

2.2.3 Instructions on powering the Product. While connecting the Product and preparing it for operation follow the steps below:

- a) transfer circuit breakers of main power switchboard to “OFF” position;
- b) connect de-energized power cable to input terminals;
- c) transfer the circuit breakers of main power switchboard to “ON” position;
- d) transfer a piano type switch “ON/OFF” on the casing to “ON” position;
- e) check the Product connection; check main power supply by green LED on the piano type switch; make sure there is no alarm on dry contacts;

f) using voltmeter, measure output voltage on connectors' contacts (for load connection); measured values shall be 12 V DC. If measured voltage is different from the rated value, the Product is not ready for operation. Contact the Manufacturer;

g) transfer piano type switch to "OFF" position and connect the load;

h) switch the Product on and check operation of load.

2.2.4 To switch the Product off:

a) switch off the load (only if a load may be switched off by a switch located on the load casing; in another case, a load switches off once the Product power is turned off);

b) transfer the piano type switch "ON/OFF" on the casing to "OFF" position, and then transfer circuit breakers of main power switchboard to "OFF" position.

3 TECHNICAL SERVICE OF THE PRODUCT

3.1 GENERAL DESCRIPTION

Before performing the TS the staff shall familiarize with the Product structure and operation features.

In order to provide safe and reliable operation for the Product, the staff shall maintain semi-annual TS.

TS is carried out on the equipment in operation.

3.2 SAFETY FEATURES

While providing TS the staff shall follow instructions, see 4.2.

3.3 MAINTENANCE ROUTINE

The list of works for all types of the TS is given in Table . Maintenance routine procedure is described in the CL, represented in Tables 6, 7.

Table 4 describes consumables required for the TS.

Table 5 – TS works

| CL № | Name of work | TS |
|----------------------------------|-----------------------------|----|
| 1 | Visual check of the Product | + |
| 2 | Test of output voltage | + |
| Note – “+” – work is obligatory. | | |

Table 6 – CL № 1. Visual check

| To be done | Routine | Man-hours per 1 Product |
|--|--|-------------------------|
| Visually examine the Product | 1 Check completeness and appearance of the Product; mechanical damage, paint defects must be absent; marking plates shall be present; legends shall be read easily 2 Clean up the Product surfaces with clean cloth 3 Remove severe contamination, parts of corrosion, oil spots from the metal surfaces – using ethyl alcohol, avoiding its penetration inside the Product; all surfaces clean dry by clean cloth and dry up 4 If varnish paint coating is damaged, polish it with sand paper, then clean with alcohol-soaked cloth, cover with varnish and dry up | 1 person 5 mins |
| Check reliability of cable and bus connection to the Product | 1 Check that connectors and attaching screws are tightened; provide further tightening if necessary 2 Check the cable intactness (no mechanical damage) within visibility | 1 person 5 mins |

Table 7 – CL №2. Test of output voltage

| To be done | Routine | Man-hours per 1 Product |
|------------------------|--|--------------------------------|
| Test of output voltage | 1 Switch on the Product power supply 2 Connect a voltmeter to output terminals of the Product 3 Supply power to the Product 4 Measure voltage on the output terminals | 1 person 15 mins |

3.4 PRESERVATION

The Product and set of operational documents are stored in preserved condition in Manufacturer's packaging boxes.

Time of representation – 2 years since the date of packaging at the Manufacturer's plant.

The preservation is done in full terms, for 2 years, applying protection and packaging.

The representation is done in heated rooms in the same order as the preservation.

The Product after representation and documents are placed in packaging.

4 CURRENT REPAIR OF THE PRODUCT

4.1 GENERAL DESCRIPTION

To provide diagnostics of the problems, see Table 8.

If a problem cannot be diagnosed or trouble shooting cannot be provided, contact the Manufacturer’s service center.

4.2 SAFETY FEATURES

Only qualified personnel, examined in occupational safety may perform repair works.

The Product must be grounded before repair works. Check the grounding of the Product.

It is PROHIBITED to put a poster “DO NOT switch on! Under Operation!”, when power supply switch is in “OFF” position.

Replacing defected parts, cards and modules when power of device under repair is ON is STRICTLY PROHIBITED

Installation, commissioning and repair works are PROHIBITED in the room, where less than 2 people present

4.3 CURRENT REPAIR

The service personnel can provide repair works as given in Table 8.

Table 8 – Possible problems/defects and troubleshooting

| Problem/defect | Possible reasons | To do |
|--|------------------------------|--|
| Piano type LED does not operate (no glowing) | No power supply | Check power cable connection Provide power supply (circuit breaker of main power switchboard might be switched off) |
| | Circuit breaker switched off | Take off casing panel and switch on the circuit breaker inside the casing |

5 STORAGE

The Product must be stored in packaging inside areas complying with the required storage conditions (+5°C to +40°C) with the concentration of dust, oil, moisture and aggressive impurities in the air within the required limits for the working areas of production facilities.

After storage or transportation of the Product below +10°C, it must be unpacked only in heated premises and left in normal climate conditions for 12 hours beforehand.

6 TRANSPORTATION

The Product must be transported in the Manufacturer's transportation package in closed means of transport.

Types of shipment:

- motor vehicle and railroad transportation in closed means of transport (covered cars, multipurpose containers);
- air transportation (in sealed and heated compartments);
- sea transportation (in dry service spaces).

The Product must be transported in compliance with transportation rules applicable for each means of transport.

During loading/unloading operations and transportation, the requirements indicated on warning labels on the boxes/packaging must be observed, and no impacts are permitted since they can affect the safety and performance of the Product.

Inside the means of transport, the packed device must be firmly secured/fastened.

7 DISPOSAL

New equipment, the parts of the Product damaged during operation, and any outage equipment must not be disposed as standard household wastes, since they contain the materials suitable for re-use.

Decommissioned and non-used components of the Product must be delivered to a special waste disposal center licensed by local authorities. You can also send an over-age equipment/unit to the manufacturer for its further disposal.

Proper disposal of Product components allows avoiding possible negative environmental and health impacts, and it also allows for proper restoration of components with substantial energy and resources saving.

During operation and upon completion of its service life, the equipment is not hazardous for health and environment

This unit must be disposed according to the rules applied to electronic devices



Any products marked with a crossed trash bin must be disposed separately from standard household wastes

8 WARRANTY

The Manufacturer is under warranty obligations in case of correct System exploitation according to the OM. The Manufacturer will not consider damage claims in case of violation of operating conditions.

More information about warranty terms you can find on the official site of “NPK MSA” LLC, section Support.

Address and contacts of the Manufacturer's service centre:

“NPK MSA”, LLC

26E, Kibalchicha str., 192174, St Petersburg, Russia

Tel.: + 7 (812) 602-02-64, 8-800-100-67-19

fax: +7 (812) 362-76-36

e-mail: service@unicont.com

**APPENDIX A
(MANDATORY)
REGULATORY DOCUMENTS**

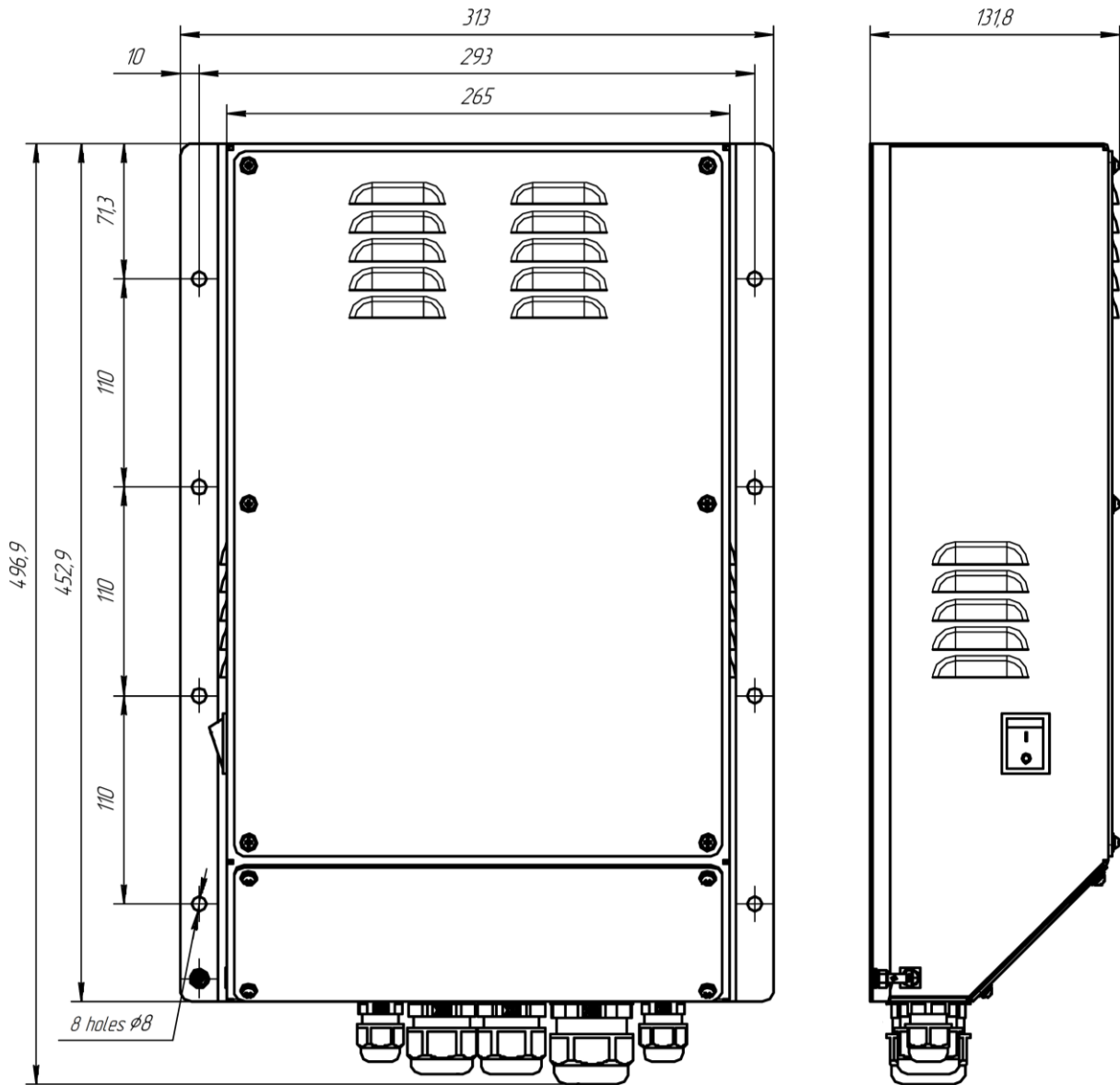

Figure A.1 – Outline and installation dimensions of the Product